



PLUTHER

1.5



DAWESOME



“

WHAT IN YOUR LIFE IS CALLING YOU?

When all the noise is silenced,
the meetings adjourned,
the lists laid aside,
and the wild iris blooms
in the dark forest.

What still pulls on your soul?

THANK YOU

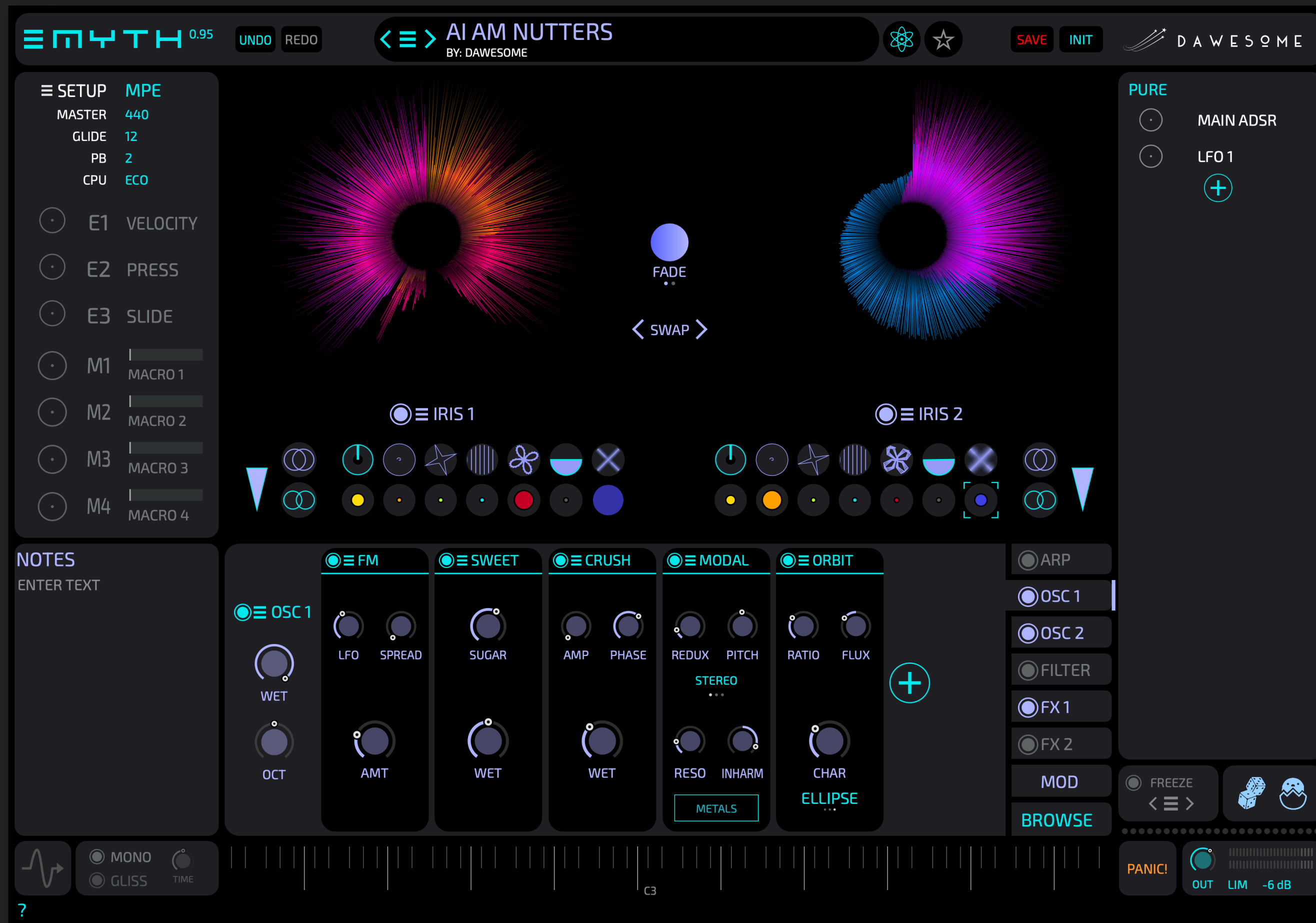

Whether you are a beginner or a seasoned sound designer - with **MYTH** you can turn your wildest sound fantasies into reality, regardless of your musical style.

The basis of **MYTH** is a novel Non-Linear-Synthesis engine that offers a paradigm shift: drag and drop audio and it will be re-synthesized as an **IRIS**. The inherent variations and richness of the sample can now be exploited with the **Transformer** dials.

MYTH was built to emulate the *joy of playing with hardware*. Forget "programming" sounds - instead you **create sounds by exploration and tweaking** knobs.



I hope you will find lots of fun and inspiration while exploring **MYTH's** exciting sonic possibilities!

All the best
Peter (Dawesome)

MYTH is the new flagship synthesizer by Dawesome.

DEMO MODE

To try the plugin simply download and run the installer via dawsomemusic.com (we don't ask you for email, registration etc.)

After installation the plugin runs in **DEMO MODE**: a mild vinyl-like crackle now and then - this is the only restriction. (and even this crackle will start only after 2-3 days)

The plugin runs in almost every DAW:
Windows 10 / 11
MacOs 13 (Ventura) onwards
VST3 AU AAX

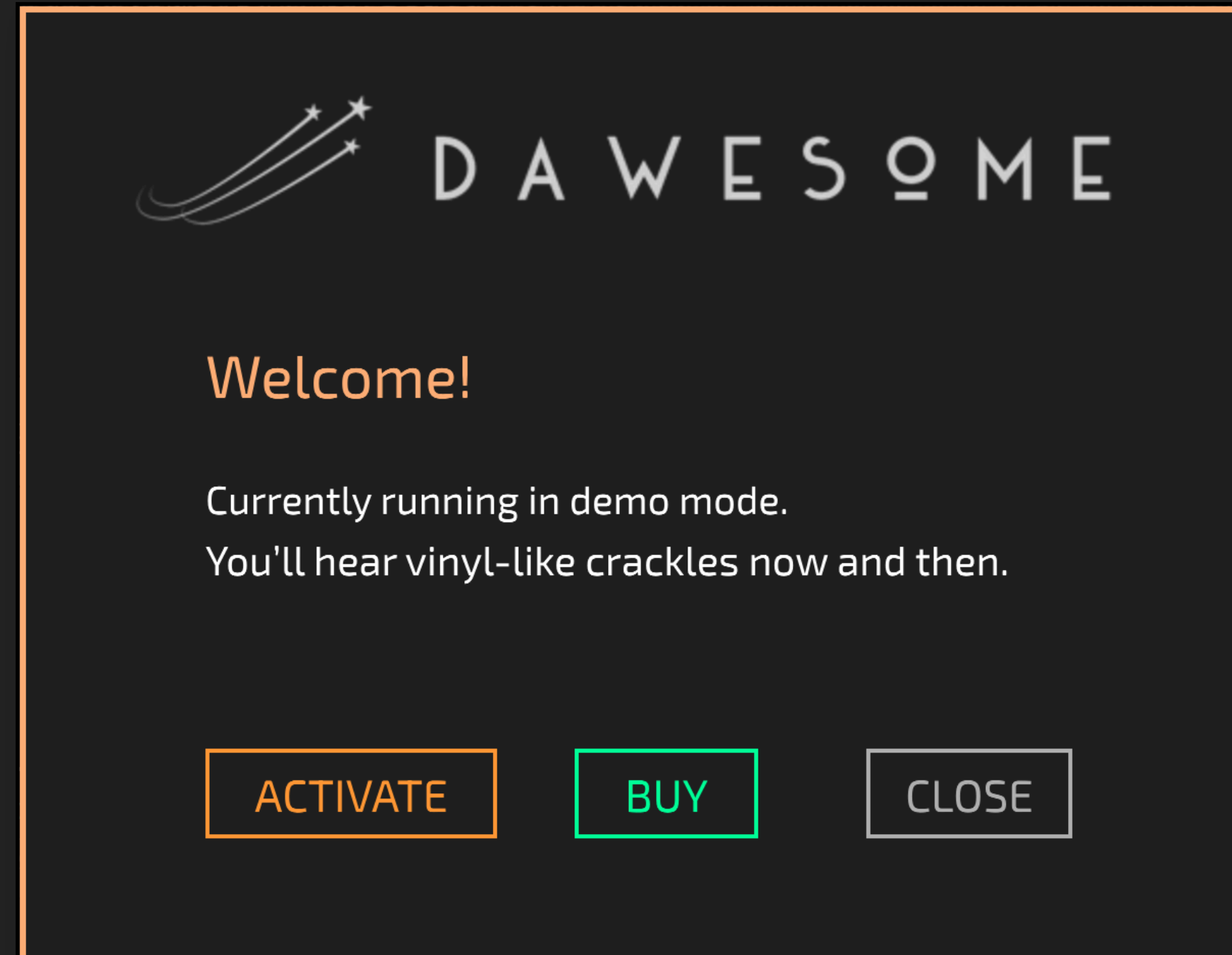

ACTIVATION



You don't need to re-install the plugin.
There is no separate demo-plugin - it is
the same installer.

Activating the plugin is dead simple:

1. Open the plugin in your favorite DAW
2. In the bottom right corner click **ACTIVATE**:



- 3a. If you obtained a **SERIAL** code (eg. via dawesomemusic.com) just paste the SERIAL and click ACTIVATE

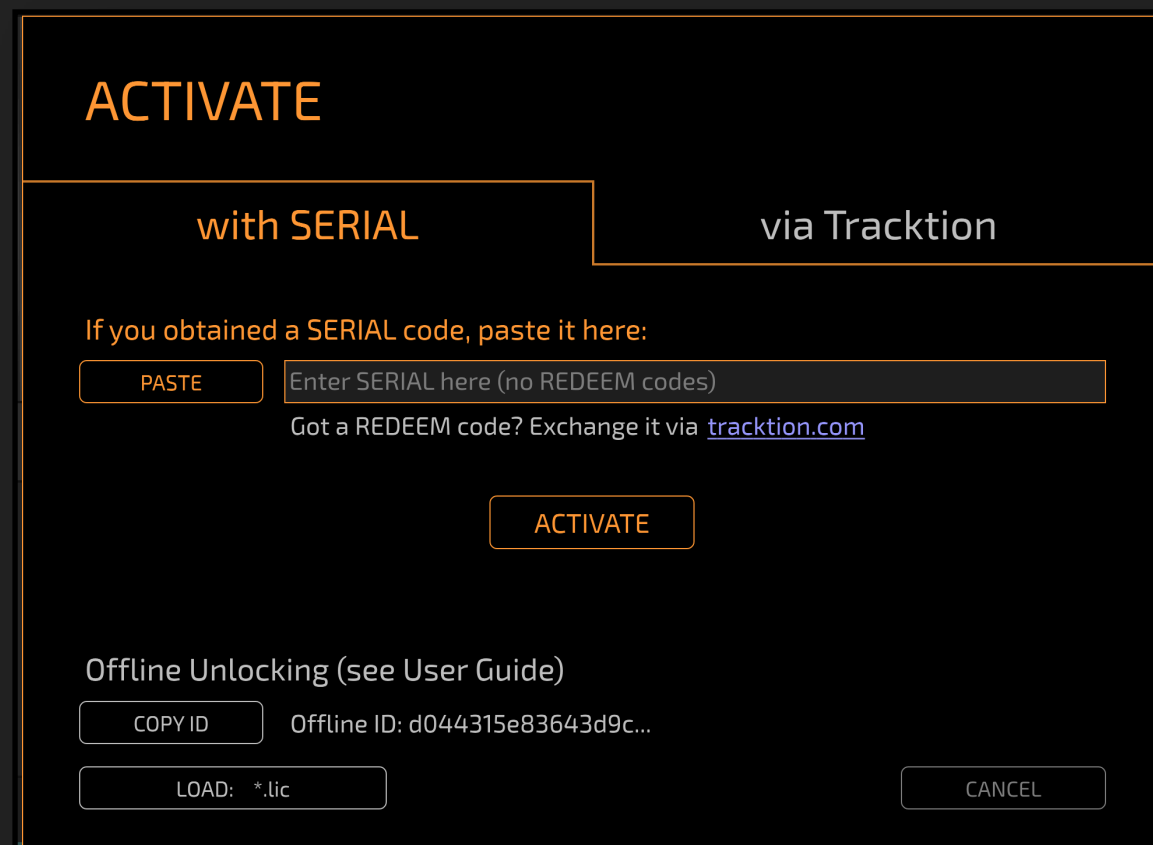

- 3b. If you purchased via tracktion.com you simply activate the plugin with your tracktion account email and password.

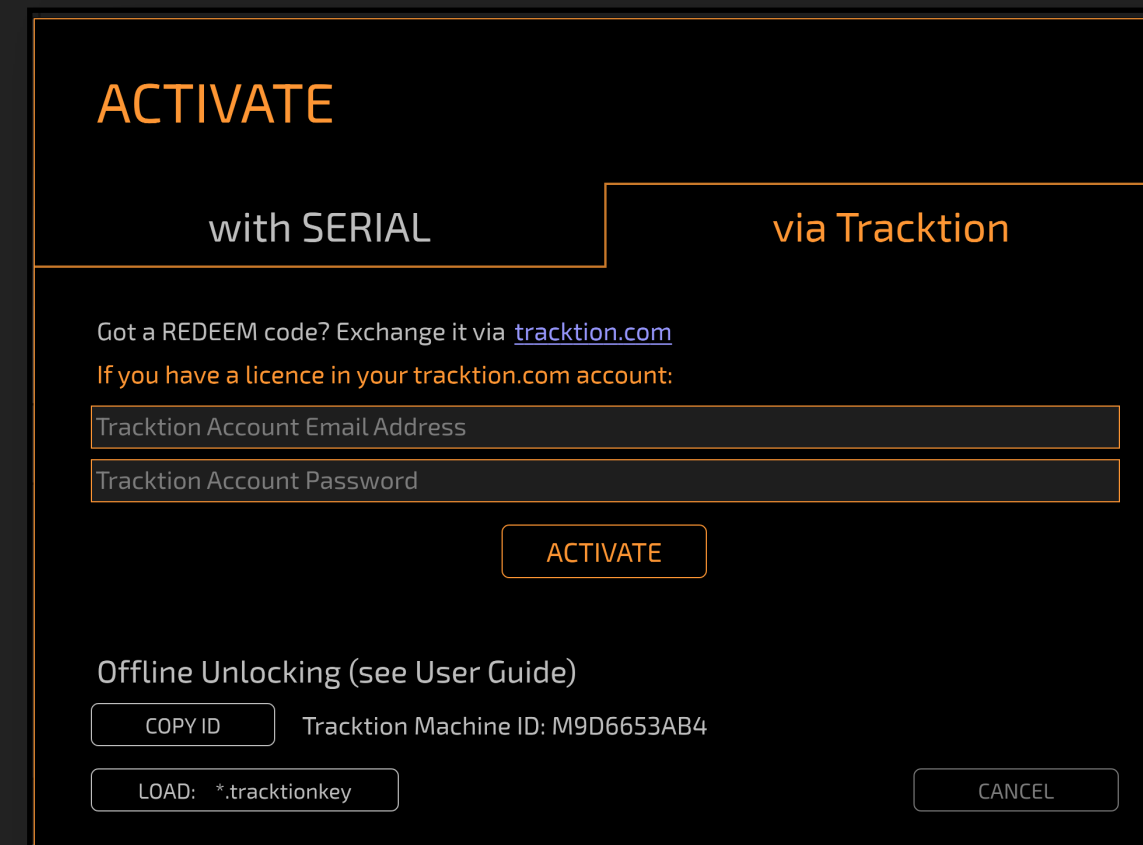

REDEEM CODES

If you purchased via a re-seller like Plugin Boutique you may have received a so called **REDEEM** code.

You first need to go to tracktion.com to redeem this code. You may need to create a tracktion account.

Afterwards you activate "**via tracktion**".

OFFLINE ACTIVATION

The normal activation needs a connection to the internet. It will then download a Keyfile that is tied to your individual machine.

(Other than that the plugin never contacts any server.)

Sometimes your studio computer is not connected to the internet - in this case you can do an OFFLINE activation. This is done in 3 simple steps.

1. copy the OFFLINE ID of your offline computer

NOTE:

please take care to choose "with SERIAL" or "via Tracktion" **correctly**, as these use different machine IDs

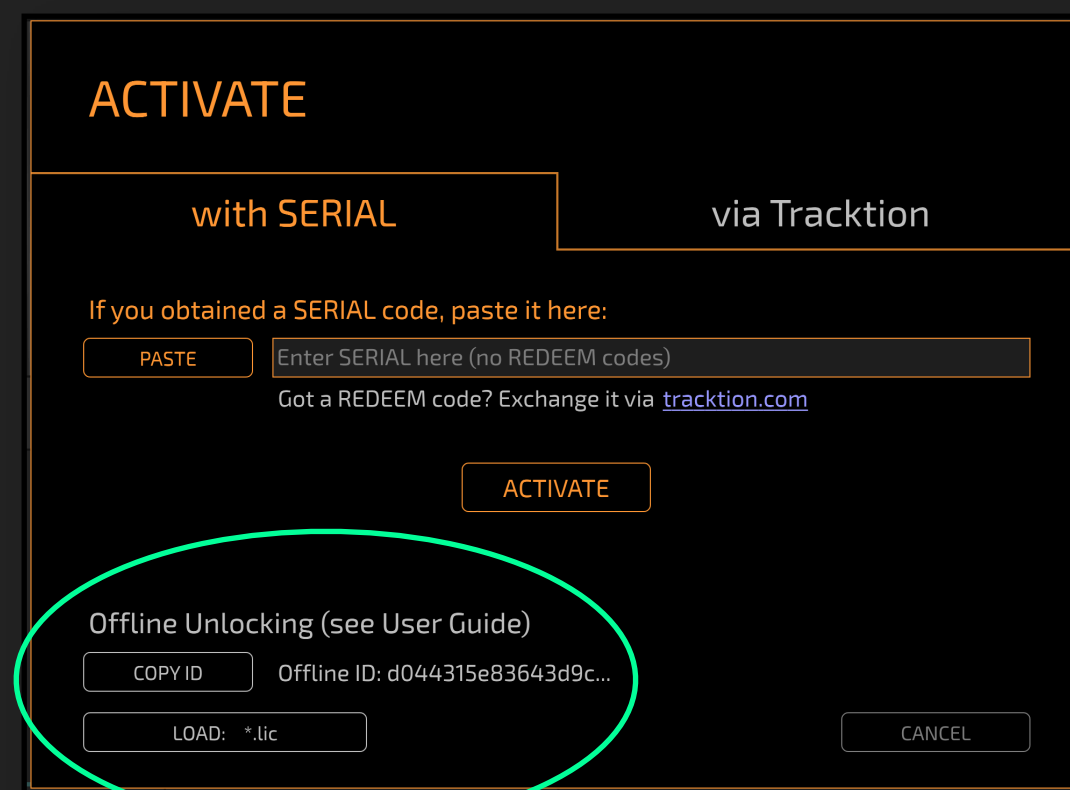

2. Download a Keyfile

If you have a SERIAL: simply go to [OFFLINE ACTIVATION](#) enter your SERIAL and the machine ID, then DOWNLOAD instantly.

If you have a license via [tracktion.com](https://www.tracktion.com): Make sure you used the "Tracktion Machine ID", not the "OFFLINE ID". You need to submit a service ticket [here](#). Provide your email address, the name of the product and the machine ID. Within a few days they will send you the Keyfile via mail.

(Note: This is a manual process handled by Tracktion and can take several business days)

3. Drag and drop that file on the plugin

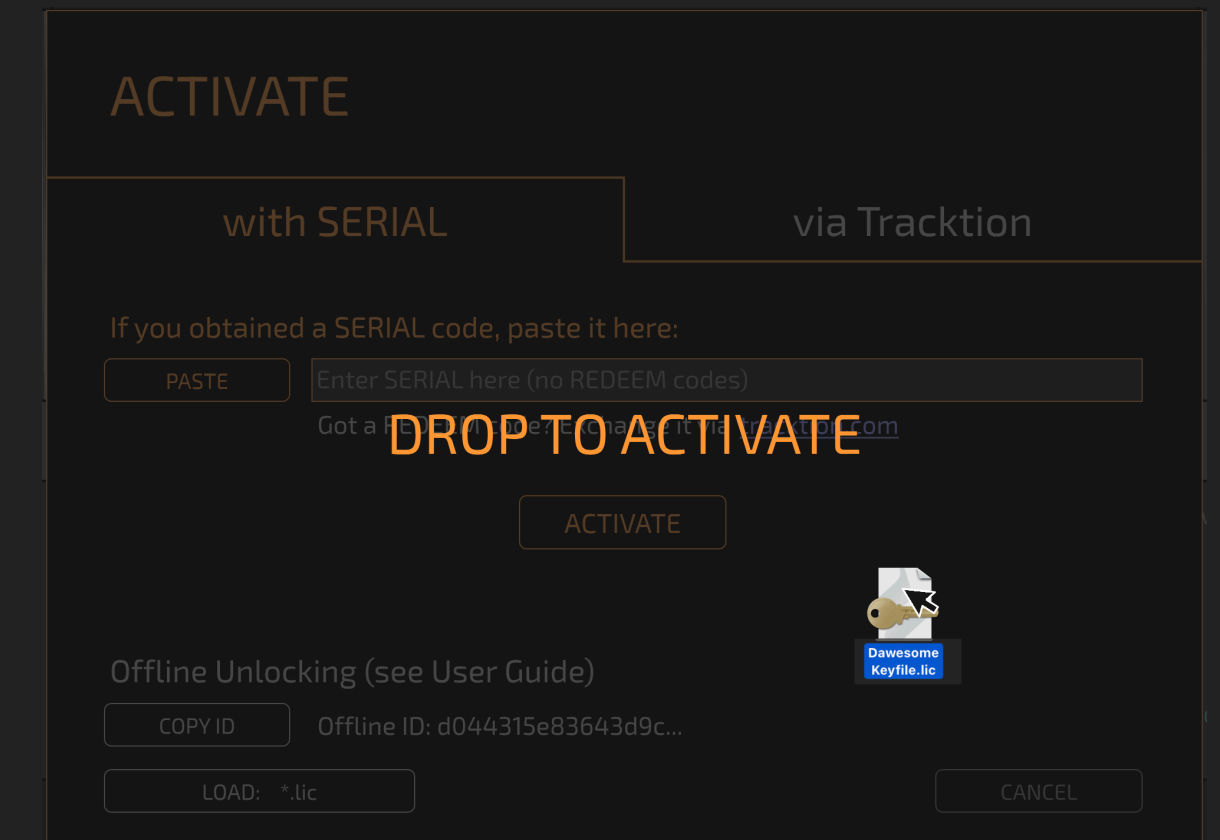

(or you click ACTIVATE and then the LOAD button and choose the Keyfile)

CHECK ACTIVATION STATUS

Activation status can be checked by clicking the 'i' button at the bottom right of the plugin UI. This will open a window showing the status of activation. If activated, the window will show if the activation was through serial number or via Tracttion. If you've lost your serial number, you may find it here!

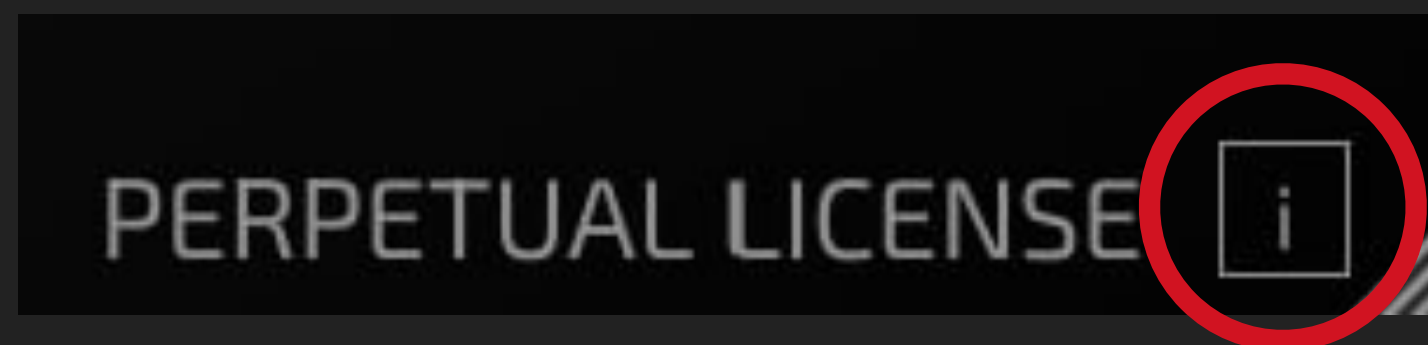
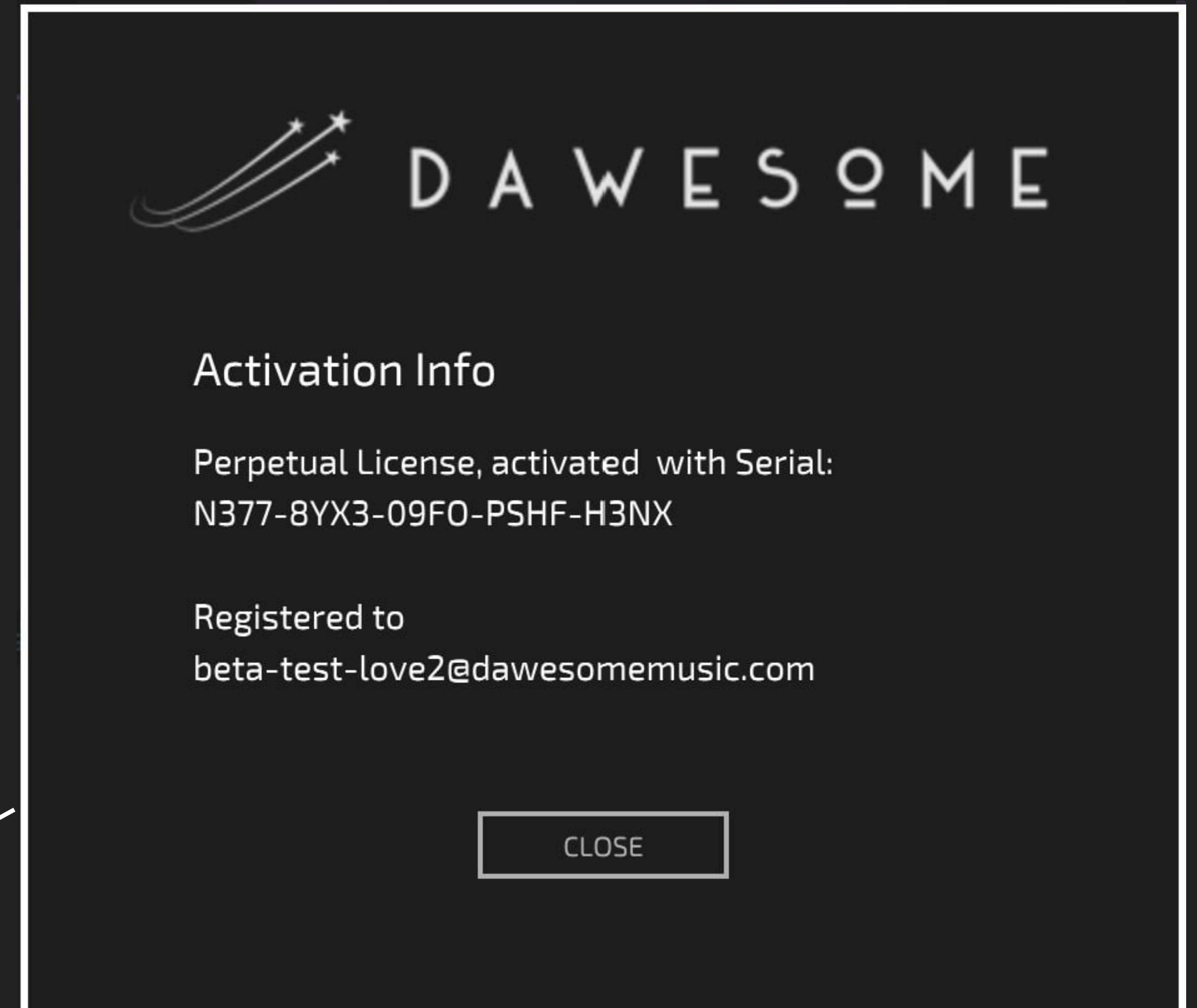

CONTENT

The Basics

[Tutorials](#)

[The Setup](#)

[Overview](#)

[Browse & Play](#)

[The Browse Tab](#)

[Save Presets](#)

The Sections

[The IRIS](#)

[Transformers](#)

[Re-Synthesis](#)

[Signal Flow](#)

[Modules](#)

[OSC Sections](#)

[Filter Section](#)

[FX Section](#)

[ARP Section](#)

Modulation System

[Modulate Parameters](#)

[Modulation Sources](#)

[Modulation Modules](#)

[Modulation: Math and Keytrack](#)

[Modulation Matrix](#)

Modules

[Analog Filters](#)

[Modal and Resonator](#)

[Wave Generator](#)

[Comb and Vowel](#)

[Sweet / J-60 / Mellow](#)

[Clouds / Reverb / Shimmer](#)

[Loophole](#)

[Grains](#)

[Orbit](#)

[OTT](#)

[FM](#)

[RM / F-Shift](#)

[Saturation / Distortion](#)

[Atari Punk](#)

[AM](#)

[Trans](#)

[BTTF](#)

[Glurp](#)

[Route](#)

Special Functions

[Mono Mode](#)

[Freeze / Randomize](#)

[CPU Performance](#)

[Preset Packs](#)

[Micro-Tonality](#)

[MTS-ESP](#)

General

[FAQ / Troubleshooting](#)

[Credits / Thank you](#)

[About Dawesome](#)

[Dawesome Village](#)

TUTORIALS

The best way to learn ... is by doing!

MYTH has built-in tutorials. A tutorial is just a sequence of presets that contain explanations.



TIP

You can stop the tutorial mode at any time either by saving your results, or by loading any normal preset.

You can RESUME the tutorial where you left off via the main burger menu ☰.

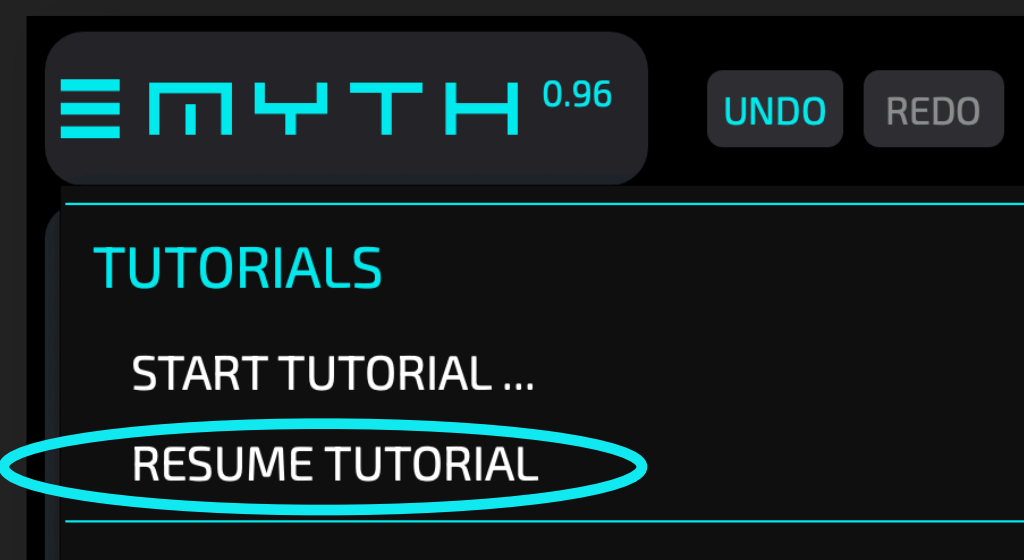

Start a tutorial via the main burger ☰ menu.

Tutorial presets are indicated by the pink color.

Click NEXT to continue with the next preset in the tutorial.

The preset notes contain explanations and instructions.

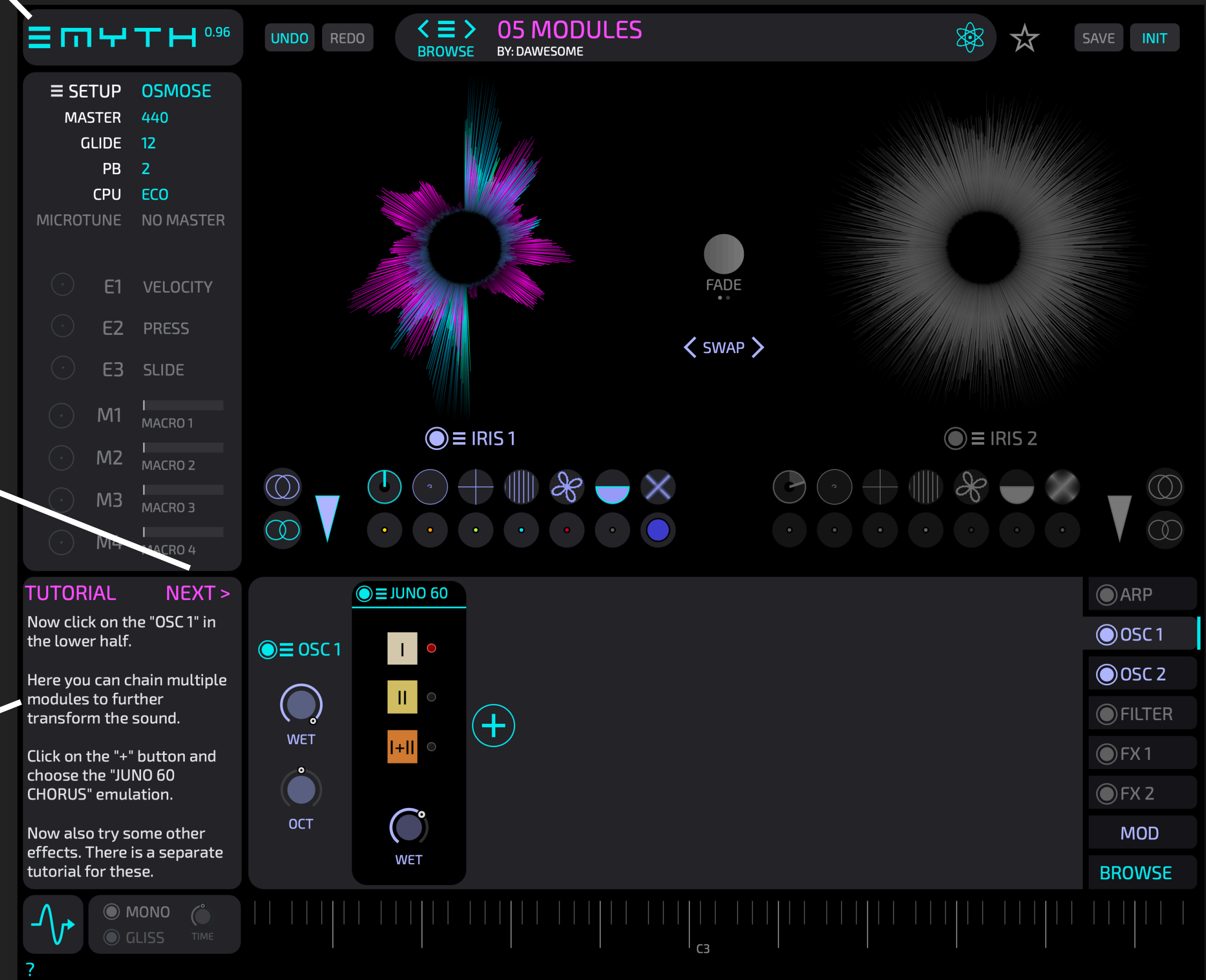

THE SETUP

The word **SETUP** may not sound very sexy, but this is really important.

Nowadays there are a variety of midi-controllers to choose from, and these come with different methods for expression, e.g., velocity, mod-wheel, MPE, aftertouch.

This creates a problem: the sound designer who created presets most likely used a different controller than you.

MYTH addresses this via the **SETUP**. You just need to tell MYTH what kind of expressive midi data is sent by your controller.



Important point: this information is stored for the plugin, not with the preset. Hence you need to choose your **SETUP** only once, and then you can browse presets and they will always match to your controller.

Click the gear symbol to choose a pre-defined setup.

You can also save the current setup.

⚙️	SETUP	SEABOARD
	MASTER	440
	GLIDE	12
	PB	2
	CPU	ECO
	MICROTUNE	NO MASTER
⦿	E1	VELOCITY
⦿	E2	PRESS
⦿	E3	SLIDE

MYTH supports the microtuning system MTS-ESP. If you use this, MYTH automatically connects to the master.

You can also configure freely to your specific needs. Right-click to choose the midi input for the main *expression-inputs*



There are two different pre-defined setups for the OSMOSE. The first one has E2 = PRESS and E3 = SLIDE. The second one uses an input source called OSMOSE which combines PRESS and SLIDE to one gesture.

You can then give this configuration a name and use the **SETUP** menu to store it.

THE SETUP - for Sound Designers

Acoustic music instruments do not simply switch notes on and off - the performer usually plays notes with *expression*.

How this is performed and how this sounds is different from instrument to instrument. On a piano you vary the speed and force when hitting a key, on a wind instrument you control the speed and pressure of the air flow and the size of the oral cavity.

MYTH uses three specific modulation sources for expressive playing:

E1 - for *NOTE-ONSET* expression

E2 - for expression via *INTENSITY*

E3 - for expressing with *TIMBRE*

How the musician physically *performs the expression* depends on their midi controller - hence this is configured here in the **SETUP**. This is the same for all presets.

How the preset *reacts to the expressive midi data* and how the sound is affected by it are saved as part of the preset.



1. For E1 you should always assume **Midi-Velocity**
2. Increasing E2 should increase the perceived intensity of the sound - in most controllers increasing E2 means that you apply more force. It feels very unnatural if applying more physical force leads to a softer tone.
3. On the OSMOSE the SLIDE is activated by pressing the key further down. That means that E3 increases only once E2 reached its maximum. Hence E2 should not create complete tonal mess if you want to offer E3

Some examples of typical controller setups that you can find in the wild: The SETUP mechanism of MYTH allows you to make sounds that translates from your setup to the users setup.

	Midi	MPE	OSMOSE	User A	User B	...
E1	Vel	Vel	Vel	ModW	Vel	
E2	ModW	Press	Press	Pedal 1	ModW	...
E3	Pedal	Slide	ModW	Pedal 2	PitchBend	

OVERVIEW

Use the main burger menu ≡ to change settings.

To get the most out of MYTH you need to tell her what kind of midi setup you are using.

[It's explained in detail here.](#)

Many presets provide Macros for further shaping of the sound.

You can enter notes for your preset.

[This is also used for the TUTORIAL MODE that is explained here.](#)

You can drag and drop the last played notes as audio from here.

Click to enable or disable tooltips

The virtual keyboard displays incoming midi notes

MYTH offers various **MODULES**, [these are explained here.](#)

The MYTH engine has multiple **SECTIONS** - [explained here.](#)

The UI is resizable. Drag to shrink or expand

UNDO and REDO of last operation

Go to next or previous patch of your current selection. [More info here.](#)

Click this to invent a name

Click to save the patch. Turns red if there are unsaved changes. [More info here.](#)

The modulation sources used in the preset. [Explained here.](#)

The **IRIS** is a core piece of the synthesis engine. You can drag and drop samples here to re-synthesize them. [as explained here.](#)

TRANSFORMERS are used to shape the sound [as explained here.](#)

The Freeze and Randomize section can be used to create new presets - [explained here.](#)

CAUTION

You need to **START TRIAL** or **UNLOCK** to enjoy MYTH. Otherwise you will not be able to save presets and you will hear occasional noise.

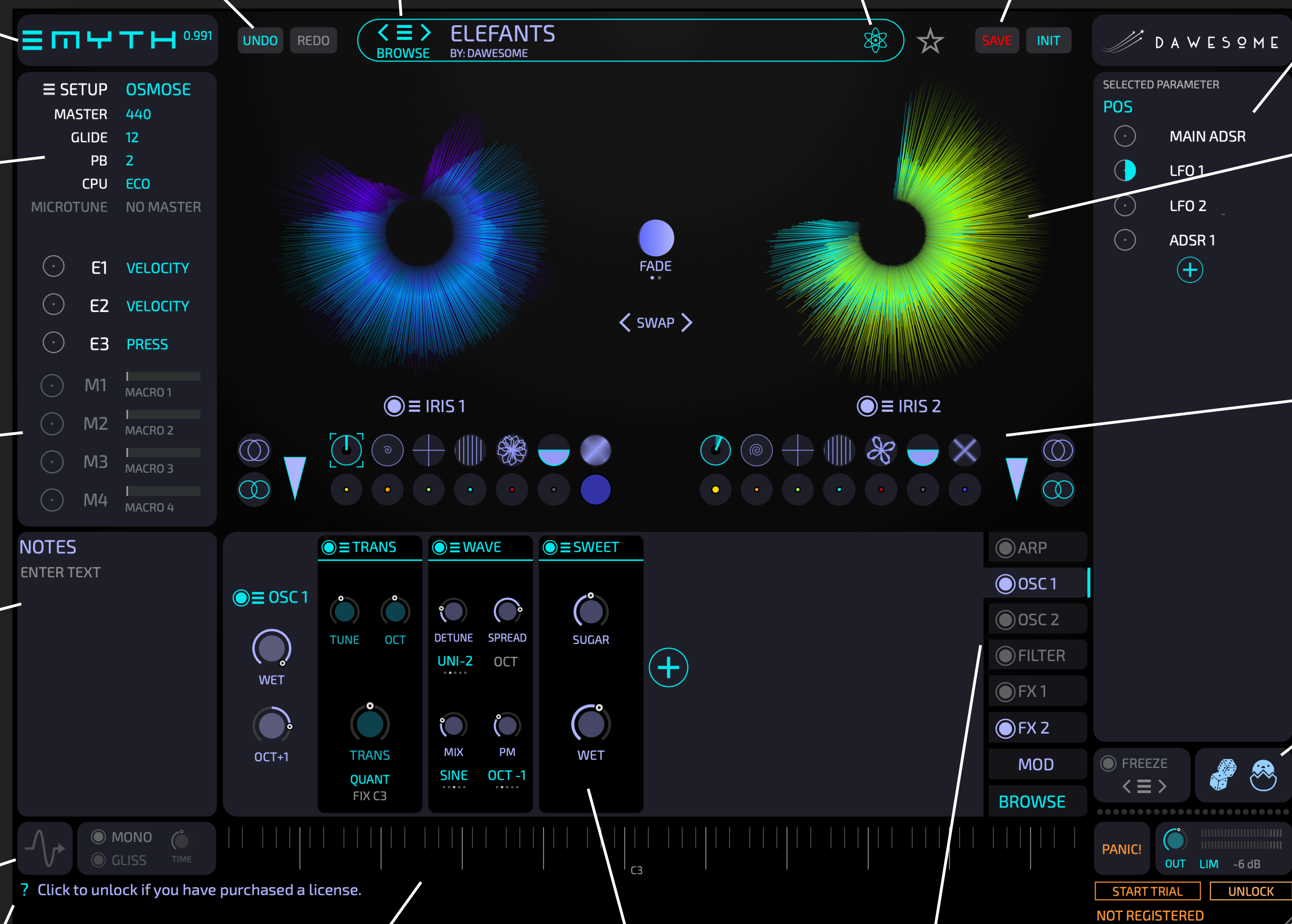

BROWSE & PLAY

The easiest way to browse presets is to use the < and > buttons. This always refers to the current selection of presets you made on the browse tab.

Click **BROWSE** to open the browse tab - this can be used to filter for a specific subset of presets as explained on the next page.

The burger menu ☰ offers quick access to a specific preset.

Click the star symbol to add the current preset to your favorites.

When you are on the BROWSE tab, presets from the current selection are shown.

Click to switch to a preset.

Click on the star symbol to add a preset to your favorites.

Right-click for a few more options.

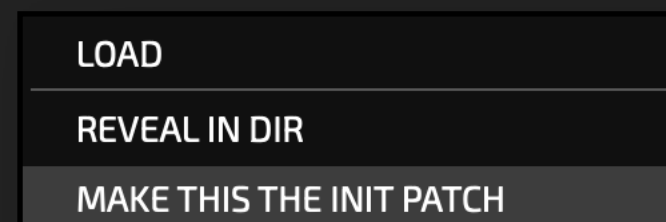

PACK	SUBDIR	TYPE	TIMBRE	CLICK TO ADD
USER	<NO SUBDIRS>	ATMO	METALLIC	
FACTORY		BASS	GLASSY	
TUTORIALS		BRASS	NOISY	
		DRONE	DULL	
		FX	RESONANT	
		LEAD	HARMONIUS	
		MALLETS	INHARMONIC	
		PAD	DISSONANT	
		SEQUENCE	RASPY	
		STRING	GRAINY	
		SYNTH	MELLOW	
			DEEP LOW	



TIP
Select any other tab to view the modulation sources.



TIP
The BREED feature is based on the current selection of presets and is explained [here](#).

THE BROWSE TAB

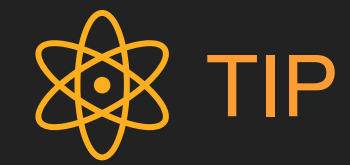

TIP

Click on the header name to change or remove the filter.

The first two filters for PACK and for SUBDIR can't be changed or removed.

In the **BROWSE** tab there are up to five filters. The first two are for PACKS and their subdirectories.

Afterwards you can add up to three more filters.

The screenshot shows the BROWSE tab interface with two IRIS sections (IRIS 1 and IRIS 2) at the top, each containing five filter icons. Below these are four filter columns: PACK, SUBDIR, TYPE, and TIMBRE. The PACK column is selected, showing a list of content including 'FACTORY'. The SUBDIR column shows '<NO SUBDIRS>'. The TYPE column lists various sound types, with 'BASS' and 'PAD' highlighted. The TIMBRE column lists various sound qualities, with 'RESONANT' and 'DISSONANT' highlighted. To the right of these columns is a 'CLICK TO ADD' section with a search bar and a 'SORT BY' dropdown menu. Further right are several filter buttons (ARP, OSC 1, OSC 2, FILTER, FX 1, FX 2, MOD) and a 'BROWSE' button. On the far right is a scrollable list of preset names, each with a star icon. At the bottom right, there are 'FREEZE' and 'BROWSE' buttons, along with some icons.

As displaced here, only presets from the FACTORY content are selected.

Only presets that are tagged as BASS or PAD pass this filter.

You can also filter with full text. Below you can set which text areas should be looked at.

You can specify the sorting order.

SAVE PRESETS

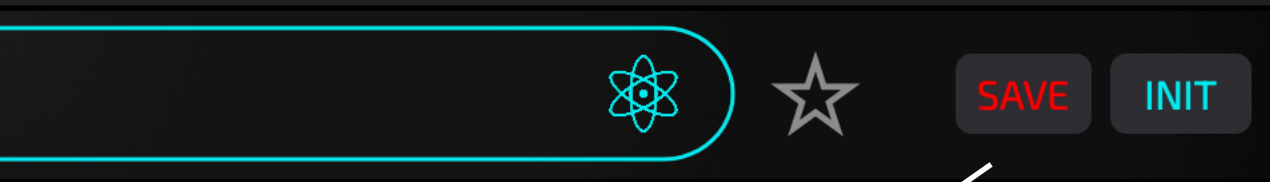

The **SAVE** button indicates with **red** color if there are unsaved changes.

When you click **SAVE** a special window opens.

Review and/or edit your preset notes.

Close the window without saving the preset. The tags and preset notes are stored internally and are not discarded.

Click to change the name of the preset

Click to choose a different subdirectory for saving

SAVE PRESET

PRESET NAME:

AUTHOR:

DIRECTORY:

NOTES:

TYPE	CHARACTER	TIMBRE	TONE	MOOD	MOTION	SHAPE
ATMO	EPIC	METALLIC	BRIGHT	JOYFUL	STATIC	PERCUSSIVE
BASS	CINEMATIC	GLASSY	DARK	LIVELY	ORGANIC	SLOW ATTACK
BRASS	ENIGMATIC	NOISY	CLEAN	MYSTERIOUS	SIMPLE	FAST ATTACK
DRONE	SYNTHETIC	DULL	DIRTY	EERIE	COMPLEX	PLUCKED
FX	MYSTICAL	RESONANT	THIN	SCARY	PULSING	SUSTAINED
KEYS	FUTURISTIC	HARMONIUS	PHAT	TRANQUIL	EVOLVING	SHORT
LEAD	VINTAGE	INHARMONIC	WARM	TENDER	HYPNOTIC	LONG TAIL
MALLETS	MODERN	DISSONANT	COLD	RELAXING	STUTTER	LEGATO
PAD	DRAMATIC	RASPY	SOFT	NEUTRAL	GLITCHY	SLURRED
SEQUENCE	AMBIENT	GRAINY	HARD	NERVOUS	ECHOING	STACCATO
STRING	URBAN	MELLOW	HEAVY		CHAOTIC	ARPEGGIATED
SYNTH	WTF	DEEP LOW	LIGHT		SLOW MOTION	
TEXTURE			AIRY		FAST MOTION	

This button appears if a preset with the same name already exists.

When you hit **VERSIONIZE** a number will be added to the preset name to avoid overwriting the existing preset.

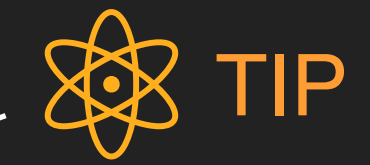

TIP
Via the **≡** symbol, you can reveal the directory where the user presets are stored. Use this to create new subfolders to organize your presets.



TIP
Sometimes it's hard to come up with a good name. Click on the **⚙** symbol to invent a name.

Right-click will provide you with a list of ten different name options. Often these names are not perfect, but spark a good idea.

SOUND DESIGN - INTRO

The IRIS is *not a sampler* - instead you should better think of it as an oscillator derived from an audio source.

Oscillators need to have a lot of overtones that can be filtered afterwards with a filter in subtractive synthesis, or to be used as an exciter for physical modeling.

Hence you will often hear, that the IRIS first sounds very harsh and noisy. This is by design ... and you will see: this is your friend!

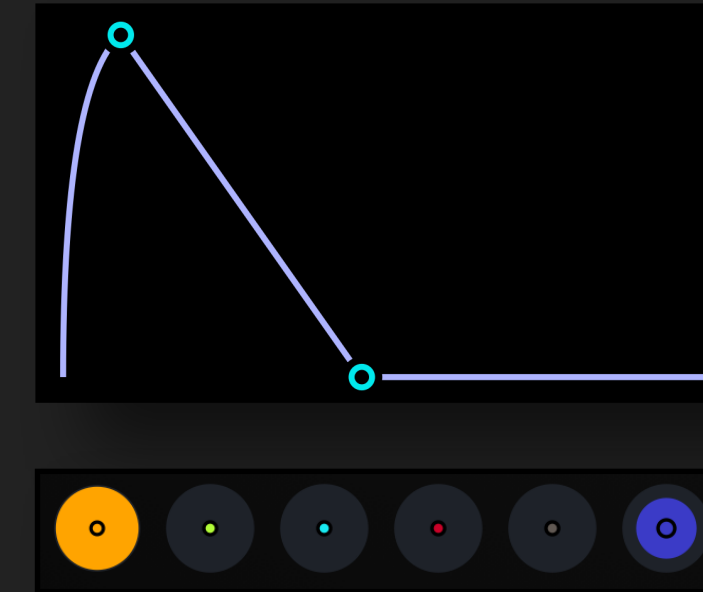
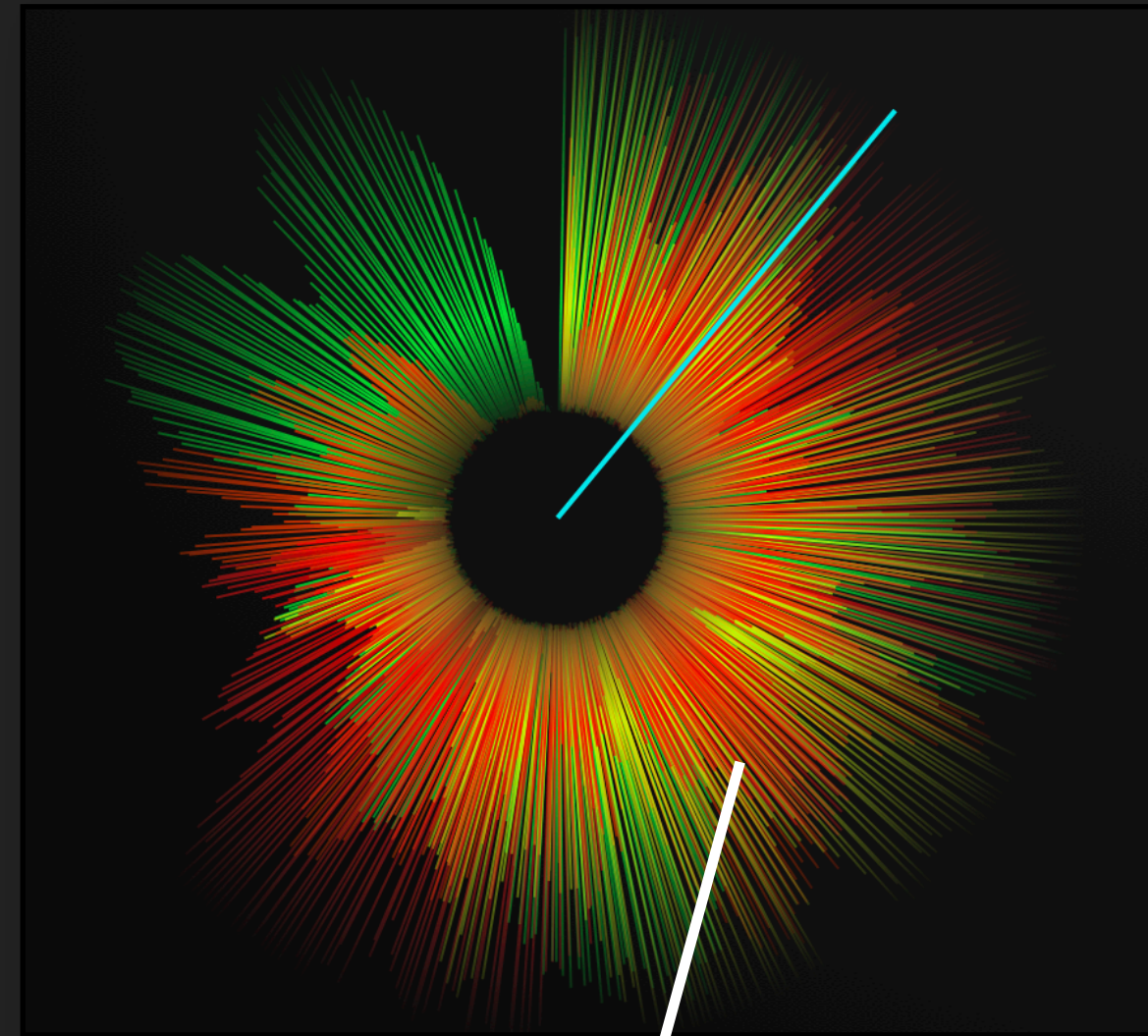

Modulate the **BLUE** transformer with a smacky ADSR such that you have no BLUE at attack and during decay it adds more and more blue. In this way you can shape natural sounding transients.

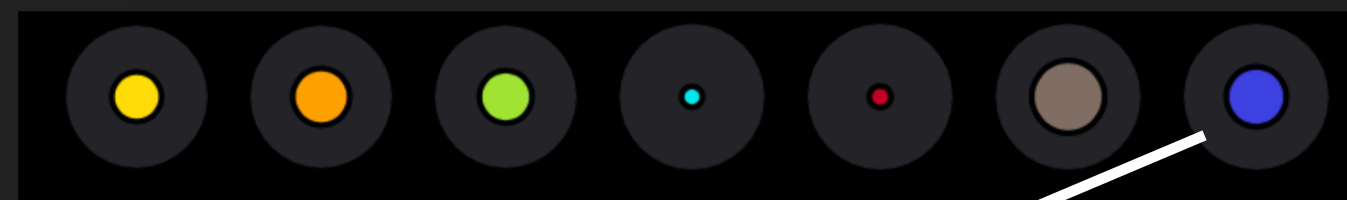

Use the **BLUE** transformer to make the IRIS softer. Then you can use the other transformers to add new overtones. Why is this useful? You can now modulate the various colours of your sound!



Hold a key on your controller and now you can click and drag on the **IRIS** to find a sweet spot. Or modulate the **POS** for example with an **ADSR** or a **LFO**



You can also keep the "harsh" sound (or even make it stronger with the transformers) and then use its power to drive a **MODAL** or **RESO** module. You can drag and drop your own samples to use as timbres - an easy route to physical modeling.



THE IRIS

In classical synthesis, oscillator waves are mostly static and you add filters and modulators to “program” variations that make the sound interesting.

MYTH offers a paradigm shift: it uses machine learning to analyze your sound material and approximate it with a *synthesis engine* displayed as an IRIS.

The inherent variations and richness of the sample and its temporal changes can now be exploited and transformed.

Instead of “programming” sounds you create sounds by exploration and tweaking knobs. Of course - you can also add classical LFOs, envelopes or filters as much as you want. Just ... you will rarely feel the need!



TIP

The easiest way to tweak an existing preset: just drop your own samples onto the IRIS!

Drag and drop your own samples onto the IRIS



The IRIS is a representation of a sound source as a loop. The start and end of the sample are at the 12 o'clock position.

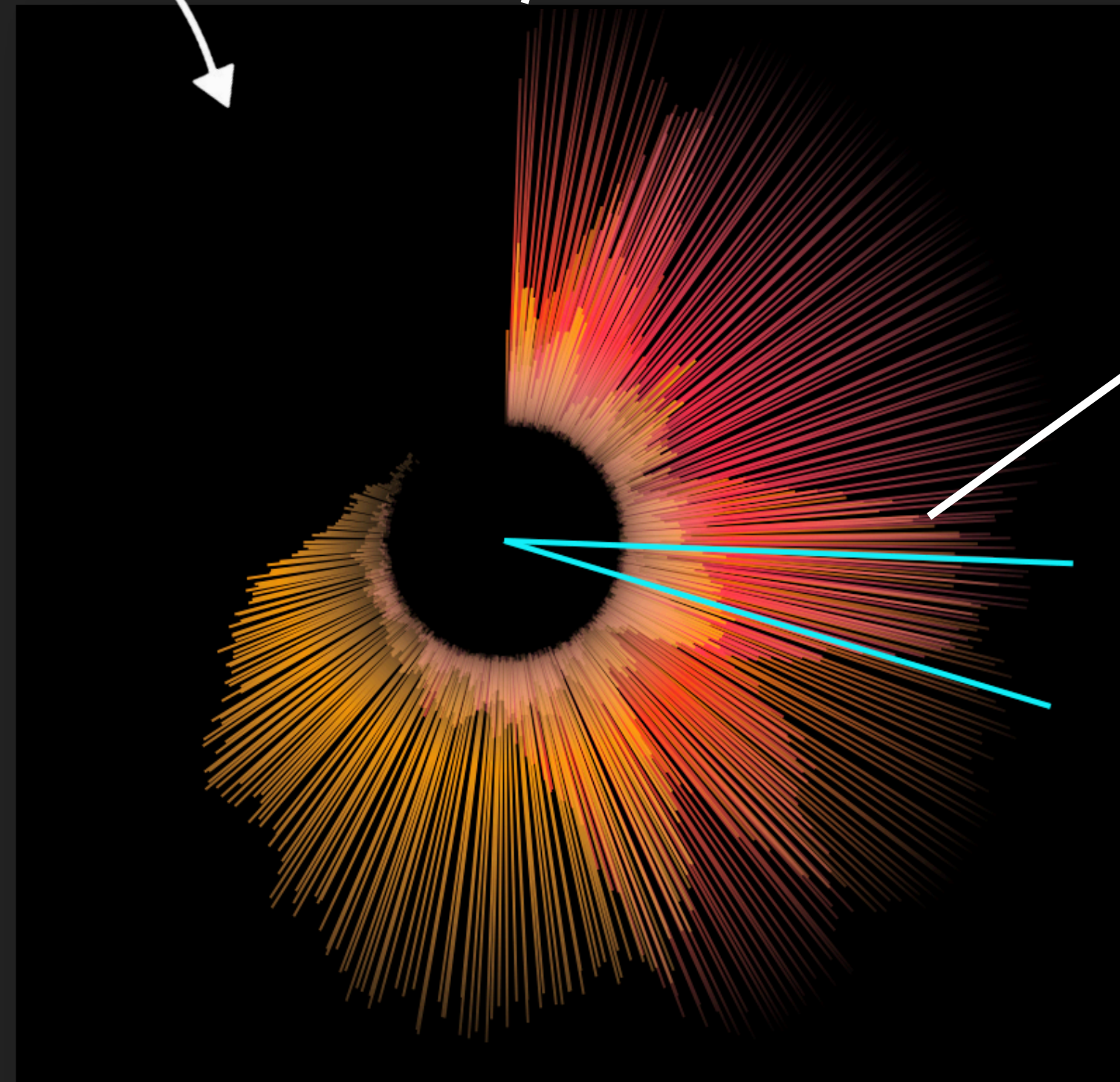

The play position for each note is indicated with a turquoise line.

You can click-and-drag the IRIS while playing to change the position.

CHOOSE AUDIO SOURCE ...
LFO
CREATE AND USE NEW LFO
SET AND USE LFO 1
IRIS
COPY -> OSC 1
SWAP
TRANSFORMERS
COPY -> OSC 1
SWAP
RESET
REMOVE ALL MODS
IRIS & TRANSFORMERS
COPY -> OSC 1
SWAP



TIP

Often, you'll want to modulate the play position with a ramping LFO. You can right-click the IRIS and choose CREATE AND USE NEW LFO from the context menu.

TRANSFORMERS

Transformers work as simple as the cutoff dial of a filter - they modify the sound and can be modulated.

The position of the "playhead" on the IRIS. The value range is two complete turns.

Animates the sound. Large values detune the sound.



FM synthesis sounds great - but "algorithms" and "operators" are not your cup of tea? In MYTH you simply apply FM as you would apply a filter.

FM adds overtones - and this can lead to pretty harsh tones. If you want softer FM you should use a good amount of PURE



SAW

Transforms the audio as if it were created with an analog SAW wave oscillator

STRING

Transforms the audio as if it were created with the physics of a string ensemble

BRASS

Transforms the incoming audio as if it were created with the physics of a brass instrument

SQ

Transforms the incoming audio as if it were the output of a square-wave osc.

SYNC

Stems from analog synthesis where two oscillators are synced. Here the nonlinear-synthesis engine creates a similar effect.

DIRT

Creates *sick* noise from your input. Can be great in itself, or to excite either the comb-filter or the modal filter.

PURE

Spectrally removes partials until only the strongest partials are left.

RE-SYNTHESIS

When you drop audio onto the IRIS, machine learning is used to re-synthesize the sample in a special way.

MYTH approximates your sample by finding the optimal combination of four static sounds whose volume is controlled by an envelope curve.

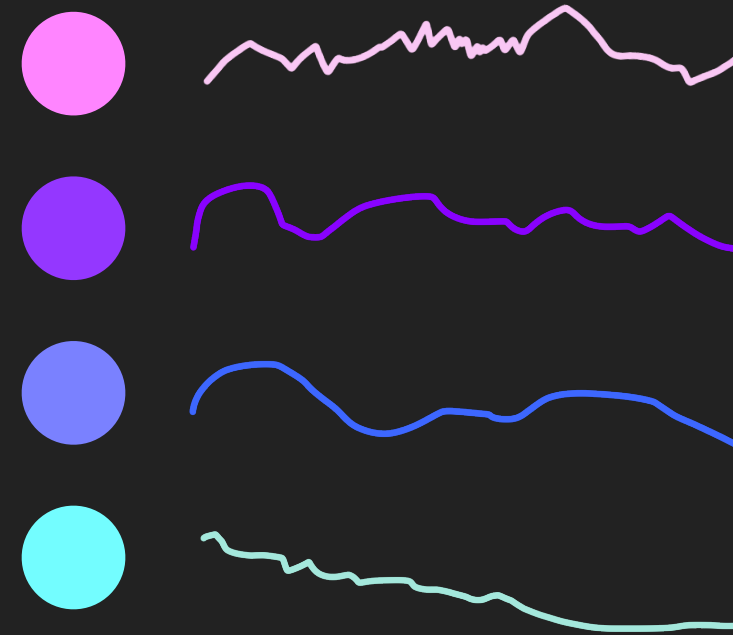

Each of the four internal oscillators of the IRIS is capable of creating any static sound.

Each of the envelopes is a MSEG with up to 500 segments.

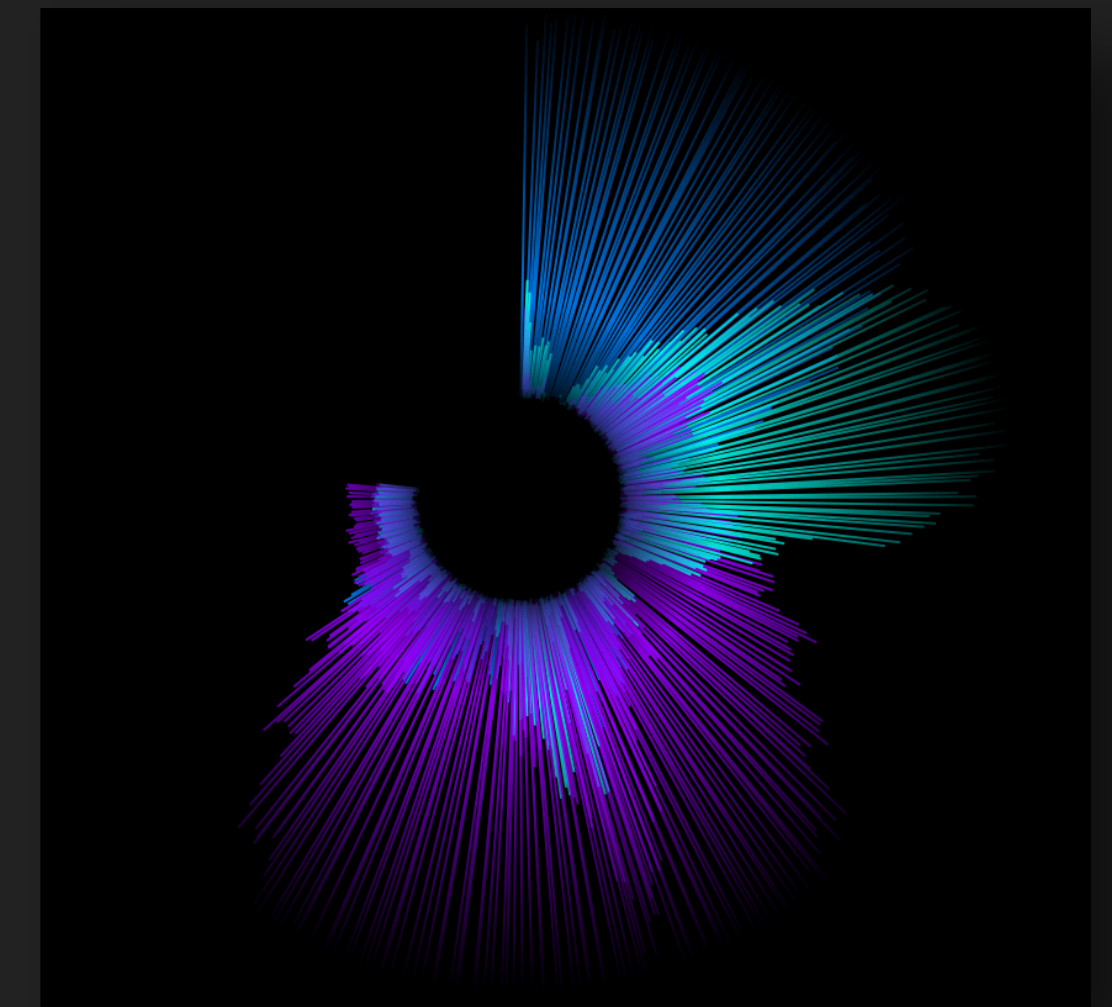

Together these are represented as an IRIS

There are two more transformers.

These don't act on the audio stream like the other transformers, instead they change the temporal evolution.

WTF

WTF changes the volume of all four internal oscillators at the same time.

If you turn it left, the brightest oscillators are faded out. If you turn it right, the darkest oscillators are.



TIP

Like all the other transformers - everything can be modulated and automated.



SMOOTH

This simplifies the envelope curve, making it smoother.

RE-SYNTHESIS ALGOS

You import audio by drag and drop onto the IRIS.

The original re-synthesis algorithm was optimized to extract timbral changes, but it is not very faithful to the original timbre in many cases.

The MYTH version 1.5 introduced a new re-synthesis algorithm, optimized to preserve the characteristics of the source material.



TIP

You can import a stereo sample such that the left channel will be on the left IRIS and the right channel will be on the right IRIS by dropping between the two IRISes.

For your convenience this will also adjust the panning and the stereo width of each IRIS accordingly.

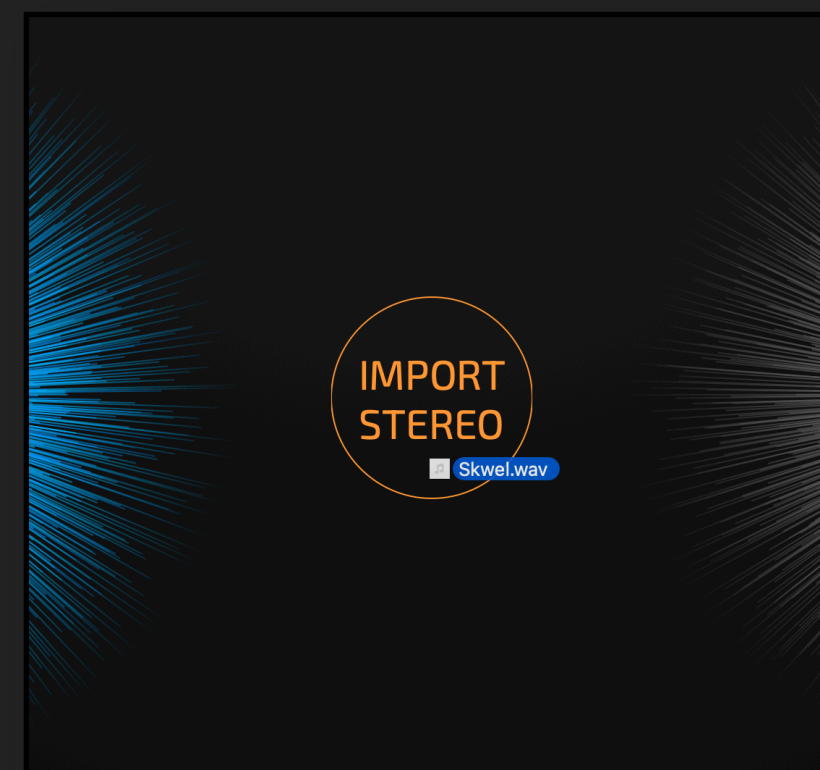

Drop audio here for the new re-synthesis algorithm.

This algorithm preserves the original timbre and offers multiple playback modes.



Drop audio here for the classic re-synthesis algorithm.

The appearance of an IRIS and its playhead will differ depending on which re-synthesis style was used.

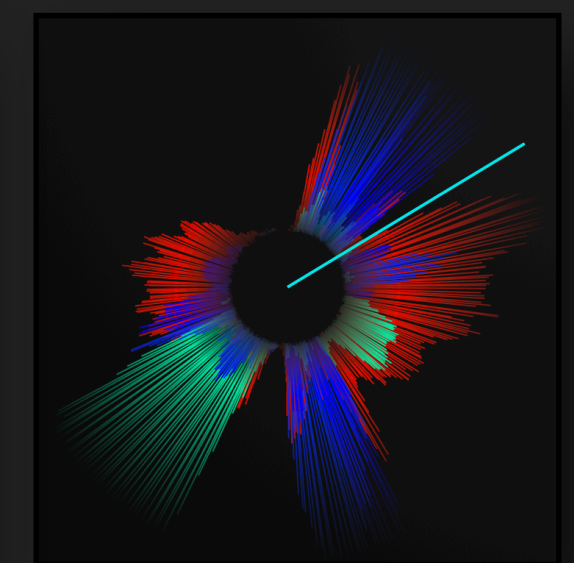
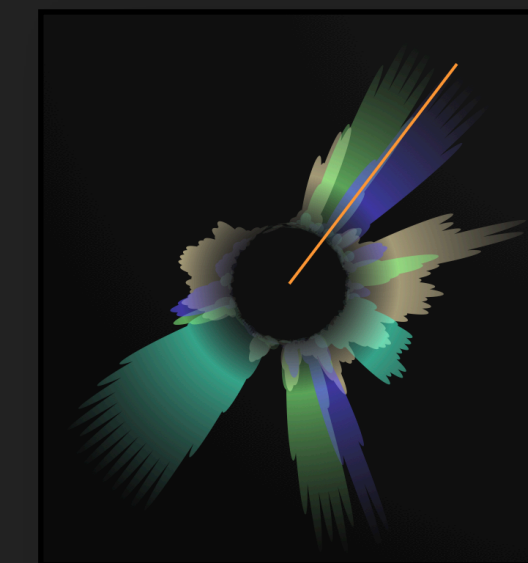

PLAYBACK MODES

If your IRIS was imported with the new re-synthesis algorithm you can choose between four playback modes.



Changing the playback mode is fast and simple, and sometimes a different playback mode gives you pleasant surprises.



Works great on wavetables and typical synth sounds.

You can export wavetables from any wavetable synth with note F, -1 octave and -23 cents. These settings usually give good results in MYTH.

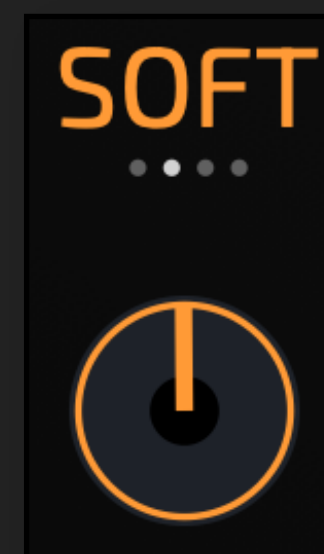

This is the "general purpose" mode for acoustic instruments or voice.

Also gives good results at very slow speeds.

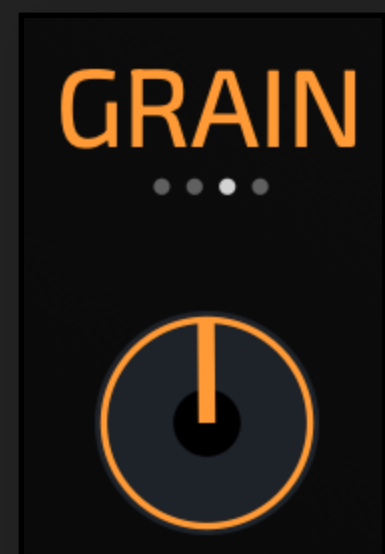

Gives very interesting result on some sources, for example drum loops.

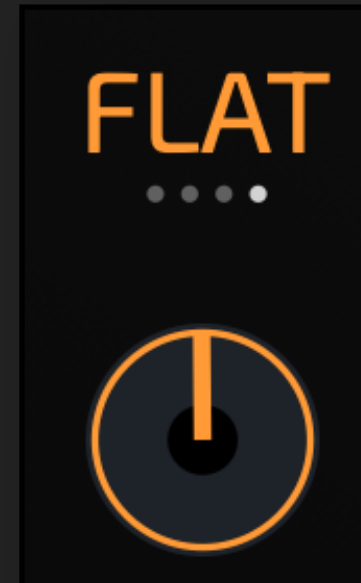

This mode tries to flatten out pitch changes.

If the signal does not contain a clear pitch, is inharmonic, noisy or the weather conditions are bad the results may not be what you expect.

SIGNAL FLOW

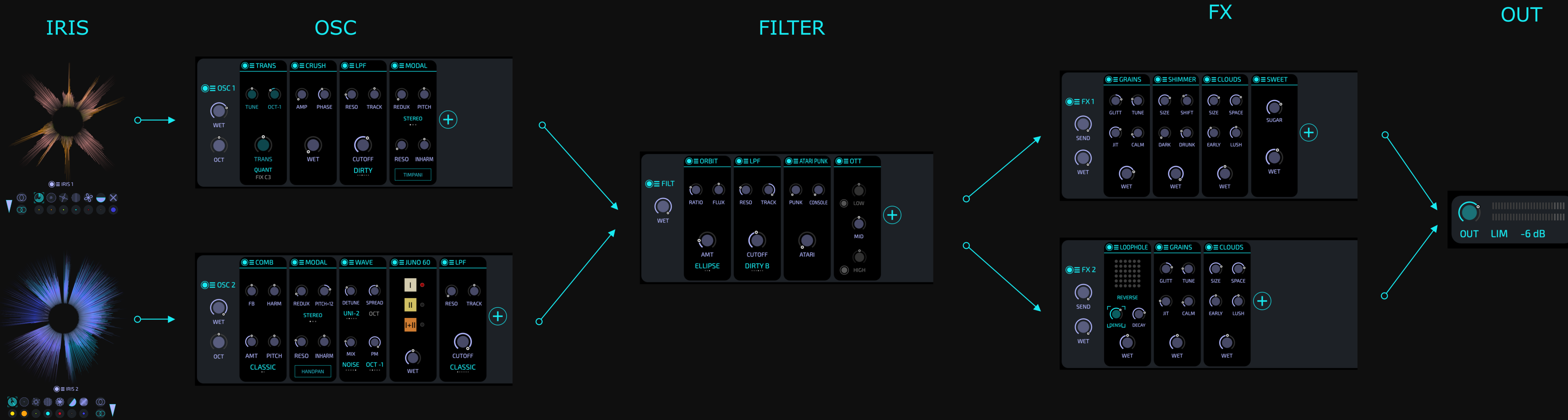

The IRIS, OSC and FILTER sections are per voice

The voices are summed and feed into the FX



TIP

The FADE knob can be used to crossfade between IRIS 1 and IRIS 2

In RING mode the signals of the two IRISes are not crossfaded, but ring-modulated.

MODULES

Modular synthesis can be very flexible, but also can get very complex with all the cables.

MYTH offers modules for great flexibility and sound shaping. The system takes inspiration from classical pedal boards - where the effects are simply *chained*.

The menu ≡ symbol offers multiple functions. For example, you can reset a module to its defaults or save the state as a named "sub-preset" for this module

Drag and drop a module by its name label to re-order. You can also revoke a module by dragging it out of view.

Click on the + symbol to add another module. Each section can have up to 6 modules.

Enable / disable the entire chain by clicking on ●

The menu ≡ symbol offers multiple functions. For example, you can remove all modules with one click, or you can save / restore the entire section as a "sub-preset".

All parameters can be automated in your DAW or modulated within MYTH [as explained here](#).



Click on any tab to switch to the currently displayed section.



Every section has its own assortment of available modules. Some modules don't make sense for polyphonic material and hence are not available in the FX sections. Some are too CPU expensive to be rendered per voice and hence are not available in the OSC and FILTER sections.

OSC SECTIONS

Each IRIS has its own section where you can do further sound shaping with modules:
OSC1 for IRIS1 and OSC2 for IRIS2

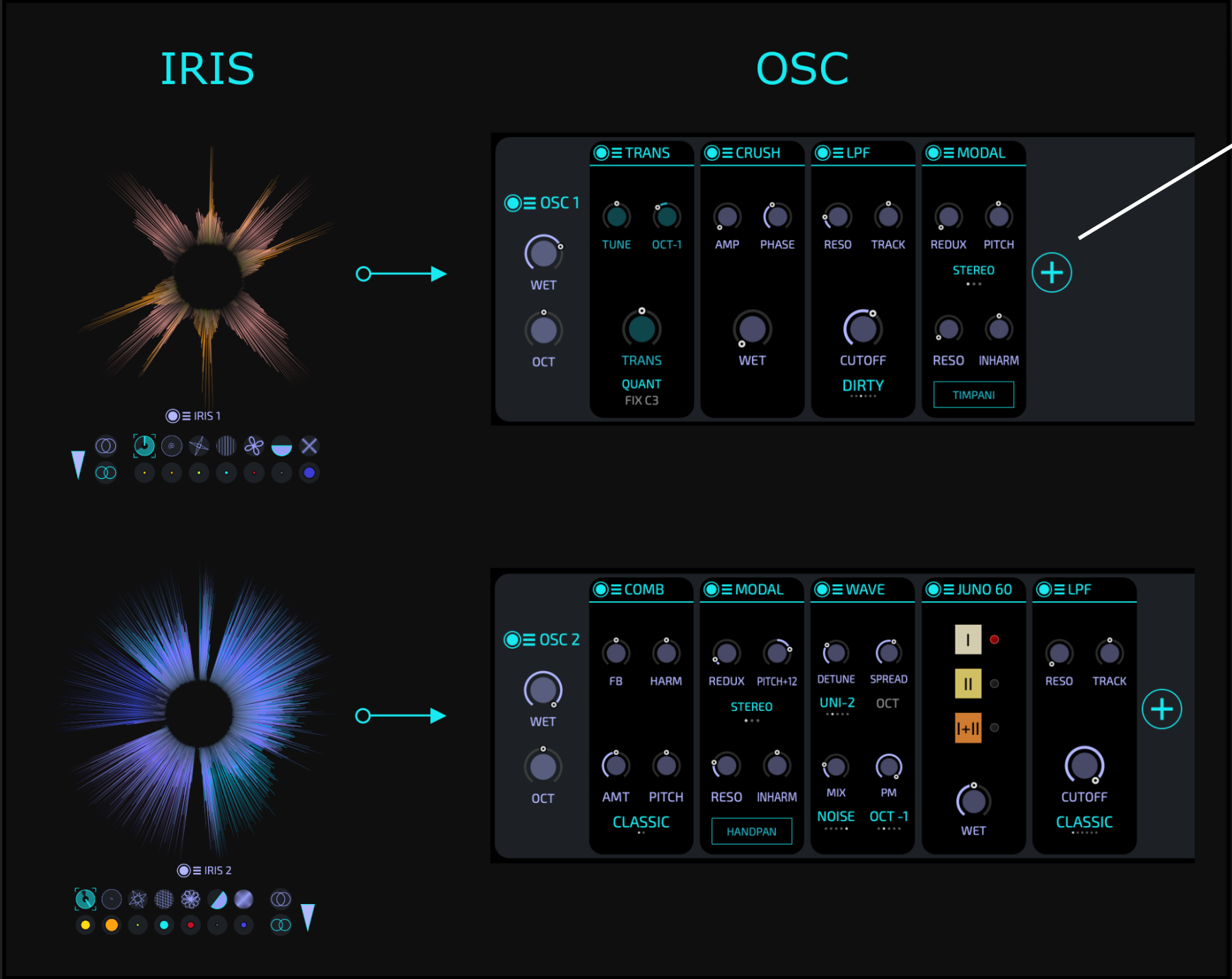

Click on **+** to open the menu of available modules.

MODULATION	DISTORT	UTILITY
BTF	ASYM	GAIN
FM	CRUSH	EQ
ORBIT	ATARI PUNK	OTT
AM	SATURATOR	TRANS
RM	GENERATION	ROUTE
F-SHIFT	WAVE	DRY-WET
FILTER	EFFEKT	
LOWPASS	SWEET	
MULTI MODE FILTER	JUNO 60 CHORUS	
COMB	MELLOW	
MODAL	RESONATOR	
VOWEL		
K-35		

If you've already used all available modules of a certain type it is grayed out in the menu.



TIP
You can also add Filters to the OSC section - there is no need to put them into the dedicated FILTER section.

- ARP
- OSC 1
- OSC 2
- FILTER
- FX 1
- FX 2

Click here to select the OSC 1 or OSC2 section.

FILTER

The two OSC sections are combined and feed into the FILTER section. Here you can place modules that shall be applied on the combined signal of OSC1 and OSC2.

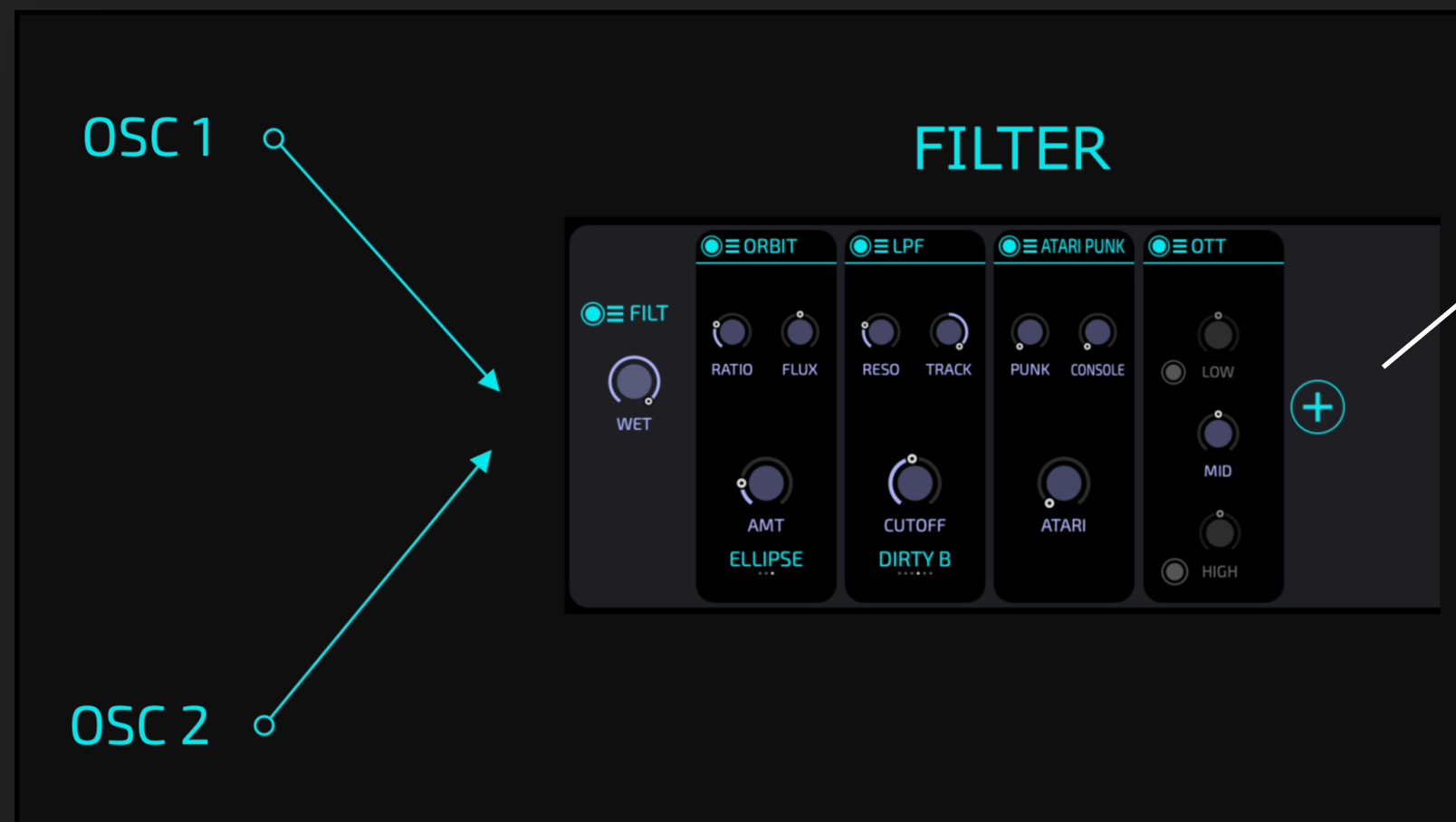

Click on **+** to open the menu of available modules.

FILTER	DISTORT
LOWPASS	ASYM
MULTI MODE FILTER	ATARI PUNK
COMB	CRUSH
MODAL	SATURATOR
VOWEL	
K-35	EFFECT
	SWEET
MODULATION	JUNO 60 CHORUS
BTTF	MELLOW
FM	RESONATOR
ORBIT	
AM	OTHER
RM	GAIN
F-SHIFT	EQ
	OTT
	ROUTE
	DRY-WET



Even though it is called **FILTER** section you can actually do much more!

FX SECTION

The IRIS, OSC and FILTER sections are per voice. After the filter section the output of all voices gets summed and fed into two parallel FX sections.

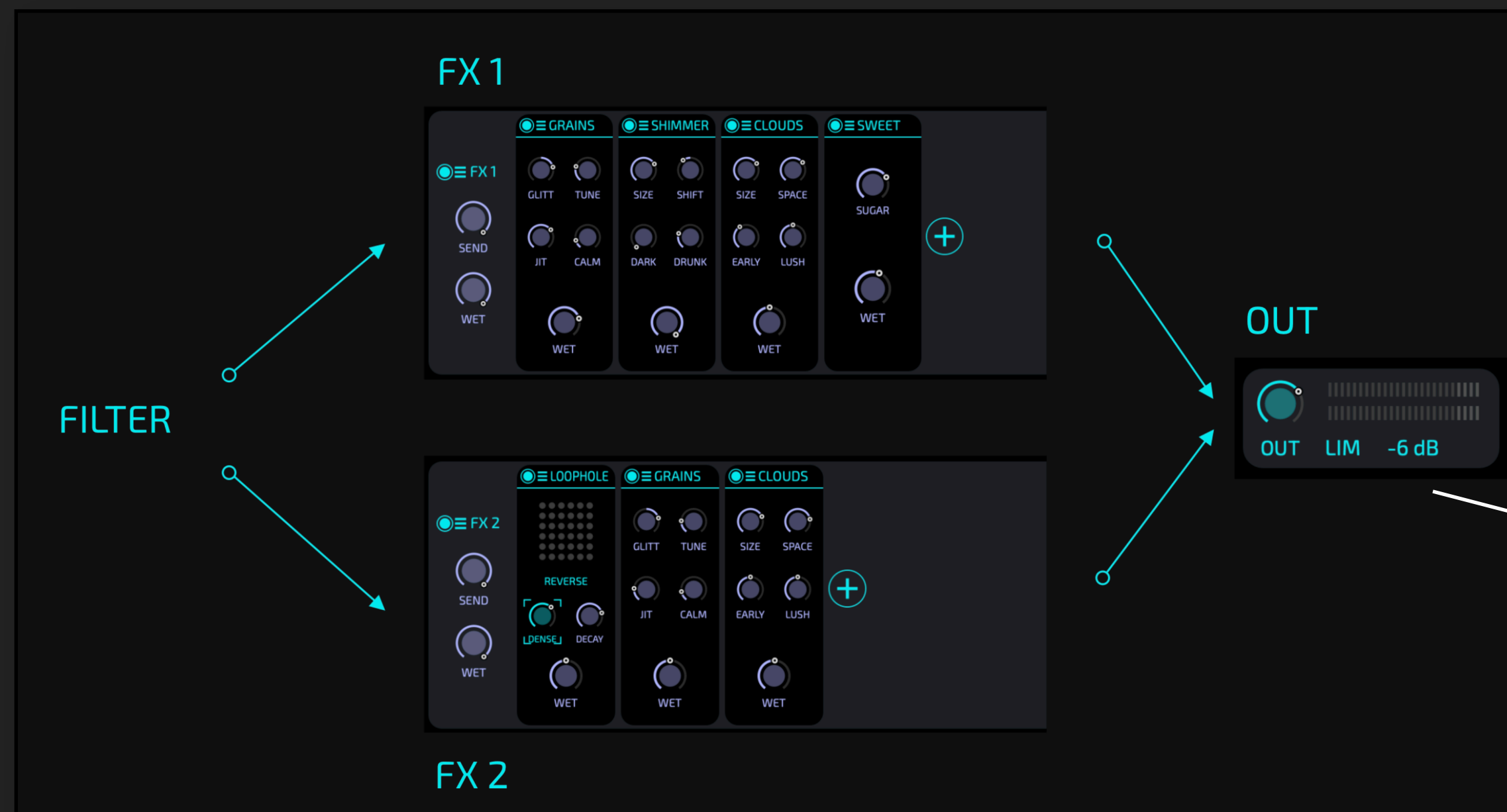

The SEND parameter determines how much of the signal is fed into the FX section.



The SEND dials are PER VOICE. You can use this for example to modulate this parameter with an ADSR, such that the note onset is not sent into the FX to stay sharp and dry.



The OUT section has a LIMITER that can also be used for sound shaping.

The -6dB switch reduces the outgoing signal by -6dB.



You should ALWAYS put a fast brick-wall limiter behind your synth when you are doing sound design to protect your ears!

ARP SECTION

The ARP section processes the incoming midi data and offers a couple of midi-modules.

The CHORD module takes one input note and creates multiple transposed notes from it. For example, here the CHORD will produce the original incoming note T, one note 3 semi-tones above, one note 7 semi-tones above and one note that is one octave below the incoming note.

In this way you can play entire chords with one finger.

The ARP module takes all notes that are currently played (either on the keyboard or through the CHORD module) as an input for an arpeggio. GATE specifies the duration of the notes. OCT adds octavated copies. There are multiple modes to choose when the ARP should re-trigger.

The SCALE device allows you to choose which pitch classes are part of the scale. You can choose from plenty of pre-defined scales by clicking on the burger menu ≡. You can define your own scales by clicking on the circles.

The TRANS module can be used to transpose the midi-notes either by octaves or by semi-tones.

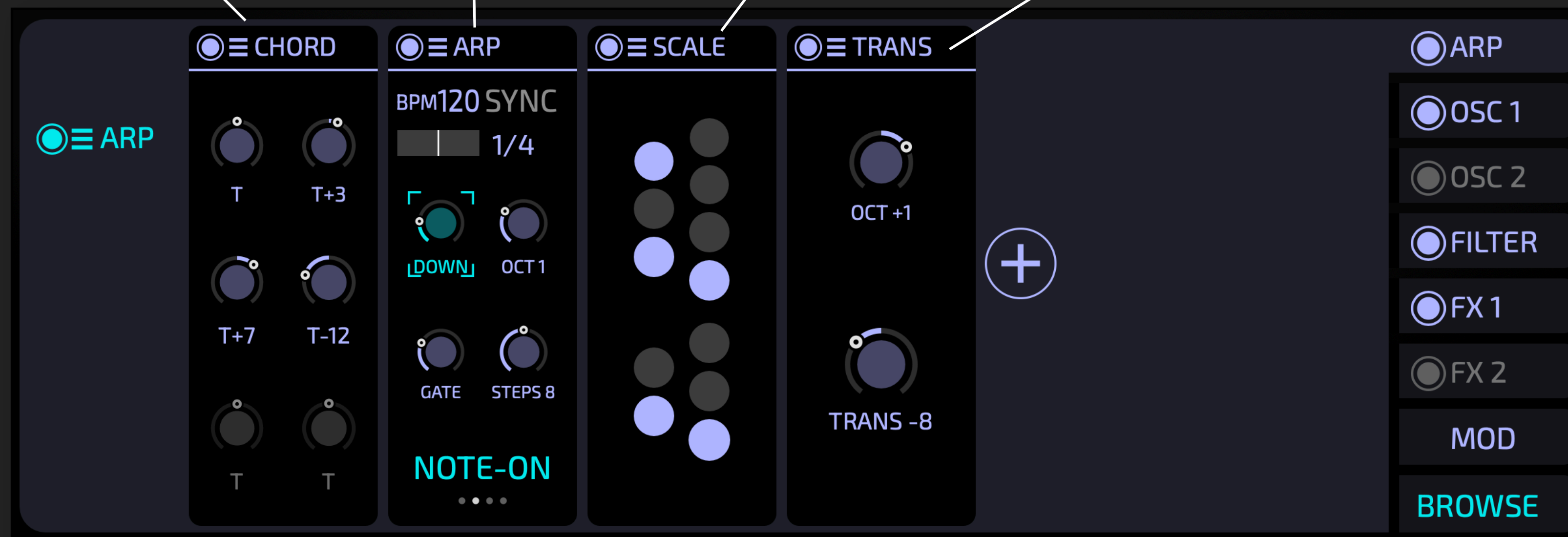

MODULATE PARAMETERS

Modulating a parameter is really simple: click on the parameter to select it. The **corners** show that this parameter is selected.

Once a parameter is selected its name shows up on top of the modulators.

Now you can choose the depth of modulation for the selected parameter by dragging the circle next to the modulator.

In this example **LFO 1** has a positive influence on **CUTOFF**. The **KEYTRACK** has no influence, and high values of **MAIN ADSR** will reduce the **CUTOFF**.

You can **RIGHT-CLICK** on a modulator to remove it and to show all parameters that are modulated by this modulator.

SELECTED PARAMETER

CUTOFF

MAIN ADSR

KEYTRACK 1

LFO 1

+

REMOVE

SELECT OSC1WAVE1MIX

SELECT FX1PHASER1FREQ

SELECT OSC1 POS

The modulation sources are listed in the right and left sidebar of **MYTH**.

You can click **+** to add a new modulator.

LPF

RESO TRACK

[CUTOFF]

ACID

.....

Click and drag a **DIAL** or **SLIDER** to change the value. You can drag horizontally or vertically.

When a parameter is modulated the colored ring indicates the current value. Every parameter can have as many modulations as you want. The modulations are added together.



TIP

When holding **SHIFT** you can fine-tune values.

Double click resets the parameter to its default value.

MODULATION SOURCES

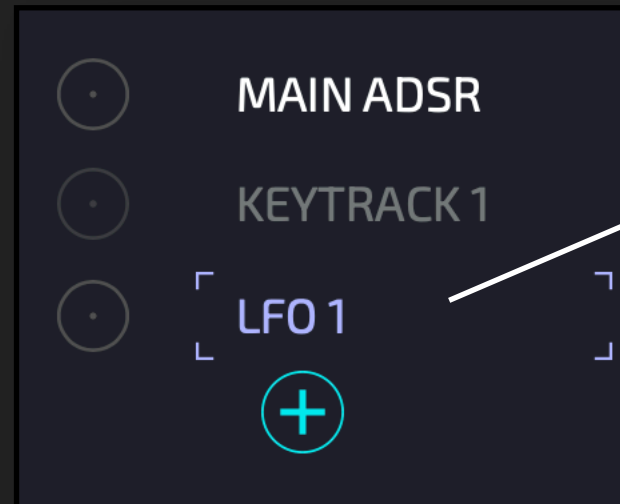

Click to select a modulation source. You can now edit the settings in the detail page.

Click to choose from multiple pre-defined waveforms for the LFO.



You can also save and restore your LFO curves here as a "subpreset".

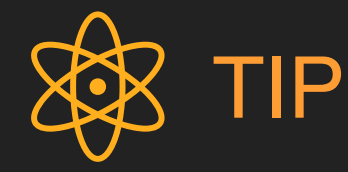

You can create and edit steps based on the grid with SHIFT-CLICK or RIGHT-CLICK.



With a few modulations you can turn any boring sound into something that sounds alive and interesting. Almost any parameter in MYTH can be modulated.

You can also modulate the parameters of the Modulators. For example, you can modulate the rate of one LFO with another LFO. This allows you to setup complex, chaotic movements in your sound.

For special purposes you can add modules here. This works exactly like the "normal" modules - they modify the incoming modulation signal.

In POLY mode each note played has its own LFO. Otherwise there is one shared LFO for all notes.

Click here to choose a different grid for snapping.

MODULATION MODULES

You can shape the modulation sources with these little modules. This can be very powerful - this is like CV modules in modular synthesizers.

CURVE allows you to shape the signals characteristic from linear to exponential or logarithmic.

With **SOFT** you can apply smoothing of the signal. You can set the time it takes to **RISE** the signal, and the time it takes to adopt to a **FALL** of the incoming signal.



You can chain multiple **JIT** modules with different settings to create unique random patterns.

JIT adds random fluctuations to the signal. You can set the **RATE** of how often the random value changes and the **AMT** of randomness added to the incoming signal.

NOTE-RANDOM creates a new random value at note-on and holds it for the entire note.

PERLIN noise works similar to **JIT**, but it creates very smooth noise, while **JIT** creates random jumps.

VISU is a visualizer for the modulation signal. Each note's signal is represented with a dot.



The **KEYTRACK** and **ADSR** modulation sources do not have their own modulation section. But you can feed their output into a **MATH** modulation source to accomplish this.

AMT simply scales the amplitude of the signal.

POS is an "extension" module for the **LFO**. It allows you to add an offset to the **LFO** position. Of course, this **OFFSET** can be modulated, e.g. by the **LFO** itself ... there are no limits.

MODULATION: MATH and KEYTRACK

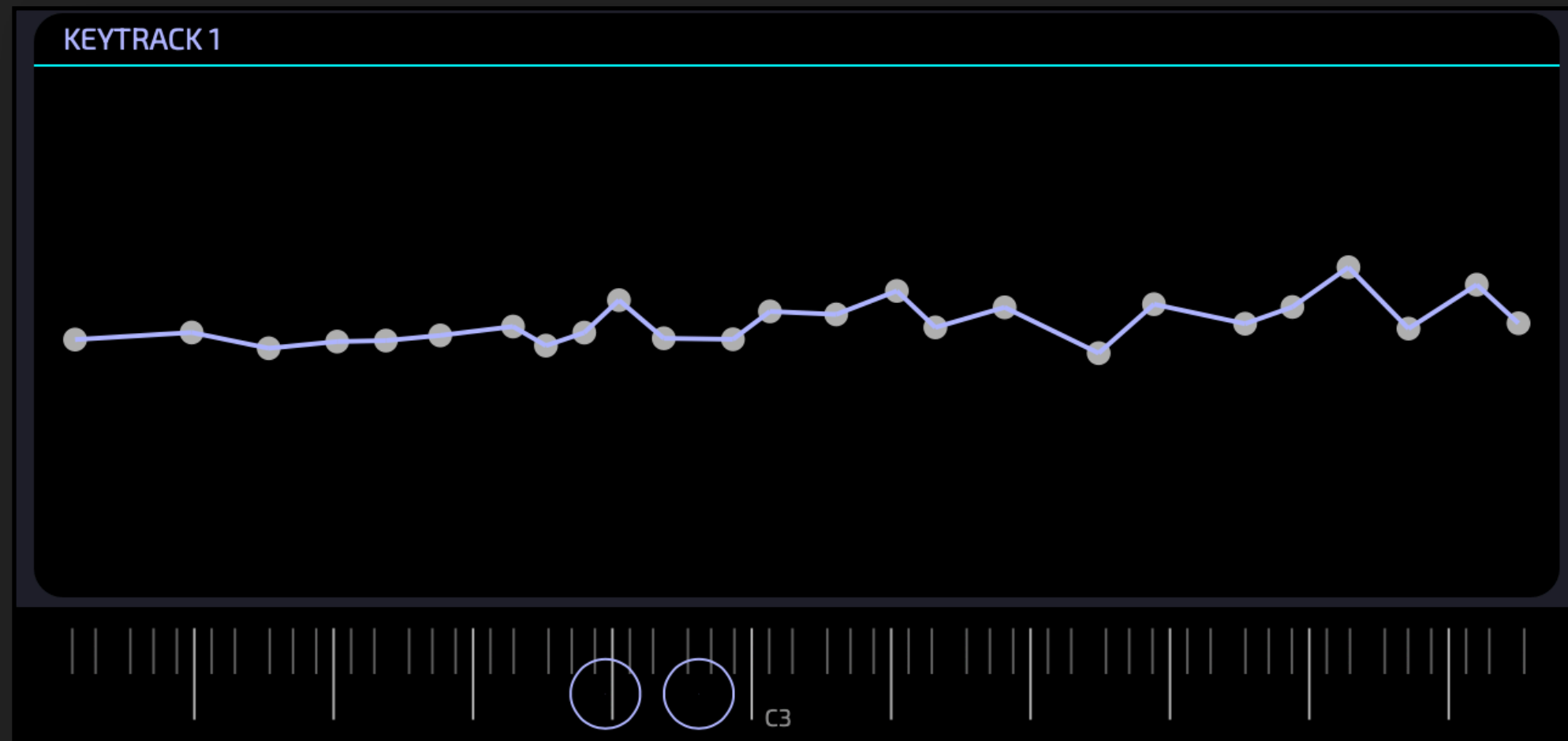

KEYTRACK takes the note input and uses a curve to determine the output signal.



In the example I draw a random curve around center. This can now be used to modulate **DETUNE** of the **OSC** - in this way every note has its own slight imperfections. Techniques like this can breathe a lot of life into your sounds.

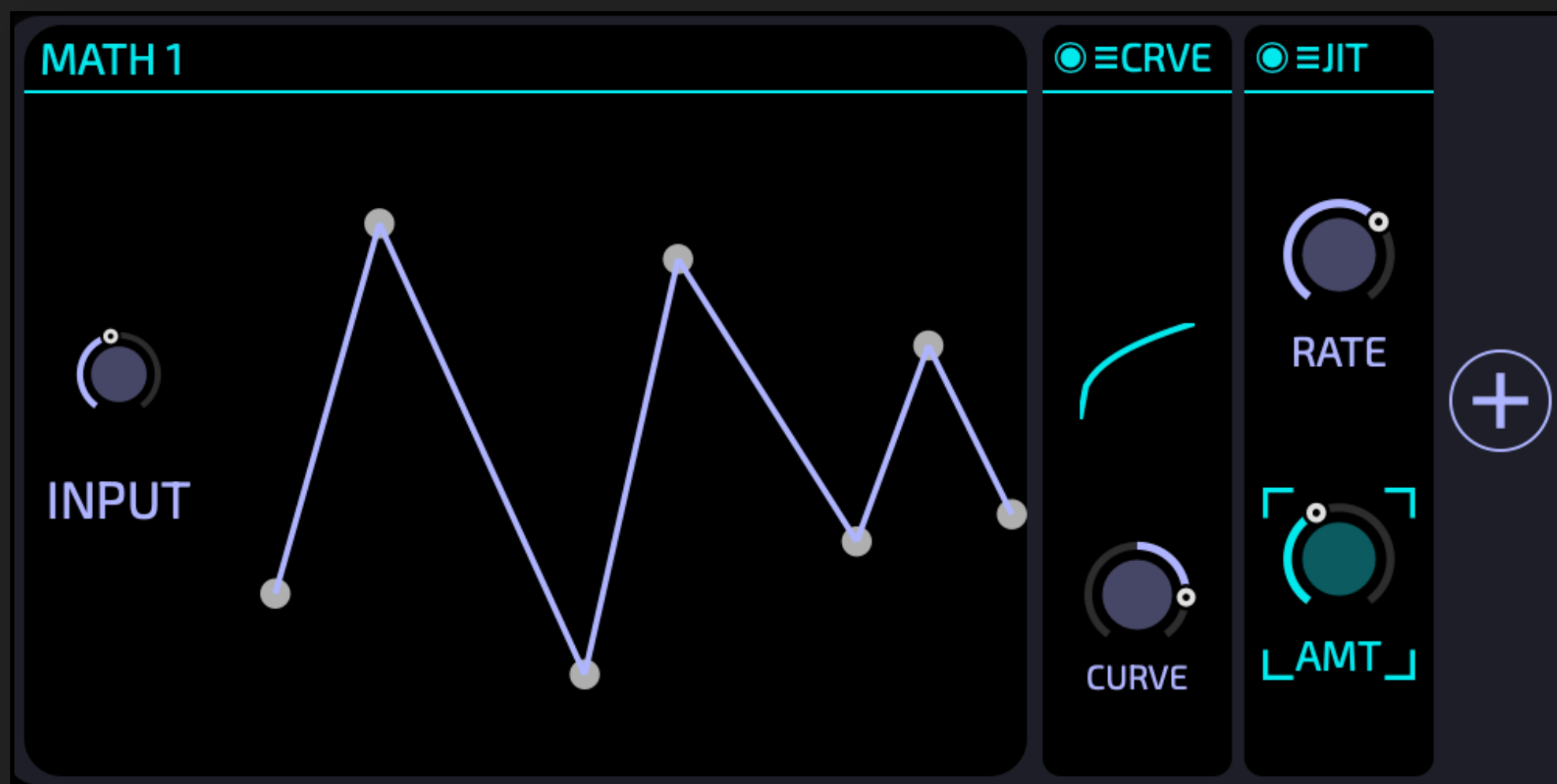

MATH has one input dial. Its value is then mapped with a curve and afterwards you can add modulation effects.

Its power starts as soon as you modulate the **INPUT** dial!



MATH opens a plethora of possibilities! For example, you can modulate its input with an **LFO** or **ADSR** and use the **CURVE** and modules to create a second modulation signal - that is still linked to the **LFO / ADSR**.

The **KEYTRACK** and **ADSR** modulation sources do not have their own modulation section. But you can feed their output into a **MATH** modulation source to accomplish this.



Like every parameter - you can modulate **INPUT** by more than one modulation source ... in this way you can create a summed signal and then process this further.

MODULATION MATRIX

Sometimes it's useful to see an overview of all modulations in the preset. For this purpose click on MOD to bring the MODULATION MATRIX up.

You can adjust the modulation depth directly here in the matrix.

This column shows the parameter that gets modulated. You can click the parameter to "jump" to the parameter in the UI and select it.

This column shows the section that the modulated parameter belongs to.

Click on the X to remove a modulation. This does not remove the modulation source.

This column lists the modulation sources.

If the modulated parameter is from a module, then the module name is showed here.

REMOVE	MOD SOURCE ▲	DEPTH	PARAM	SECTION	MODULE	
×	E 2		STRING	IRIS1		<input checked="" type="radio"/> ARP
×	E 2		DEPTH	OSC1	MELLOW 1	<input checked="" type="radio"/> OSC 1
×	E 3		SYNC	IRIS1		<input type="radio"/> OSC 2
×	LFO 1		POS	IRIS1		<input checked="" type="radio"/> FILTER
×	LFO 2		CUTOFF	OSC1	LPF 1	<input checked="" type="radio"/> FX 1
×	LFO 2		POLE	OSC1	MELLOW 1	<input type="radio"/> FX 2

MOD

BROWSE

Click on MOD to bring up the modulation matrix.

MODULE: ANALOG FILTERS

There are multiple filters that use virtual analog modeling.

The **LPF (LOWPASS)** module has multiple classical low pass modules with very different sound characteristics ranging from clean to dirty and screaming.

TRACK turned fully right shifts the **CUTOFF** frequency with the note you play.



Put the filter into self-oscillating mode by using high resonance to use it as a generator. Turn **TRACK** fully right. To tune, add a sine generator after the filter (**WAVES** module) and tune the **CUTOFF** by ear.

This is a virtual analog highpass with lots of character. Its design is inspired by the KORG-35 filter that was used in their iconic MS-10 and MS-20 synths.



A lowpass filter that is inspired by the KORG-35 can be found in the lowpass module and is called "CREAM"



This is a classical 4-pole ladder design that can be configured to work as a lowpass, highpass, bandpass or bandstop (notch) filter.

It can be run in a dual configuration with two filters either parallel or serial. The **OFFSET** parameter determines the difference between the two **CUTOFF** values.

MODULE: MODAL and RESONATOR

The MODAL and the RESONATOR modules are twins. Both use a so called "modal filterbank" - 32 bandpass filters in parallel. This filterbank can be "trained" by any sample via drag-and-drop.

MODAL is always tuned to the pitch of the incoming notes so it can be used to create the pitched part of your sound.

REDUX damps more and more of the resonators until only the strongest resonance is left.

RESO controls how easily the resonators respond and how long they "ring".

INHARM can be used to add in-harmonics to the sound.

PITCH transposes the entire filterbank lower or higher.

RESO is a resonator with a *fixed pitch*. This is great to add character to a sound



TIP

The fun starts when you use your own samples to train the modal filter bank - you can simply drag-and-drop a sample. MYTH will derive a "fingerprint" that is saved with the preset, access to the source sample is not needed.



TIP

MODAL has no DRY/WET. If you need this: use a RESO instead with TRACK turned fully right.

Click here to train the filterbank to a specific sample.

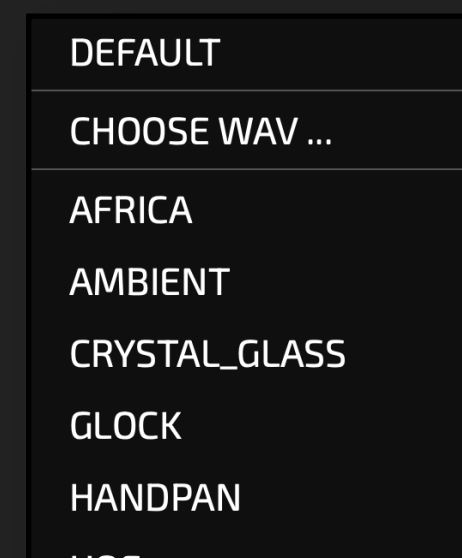

MODULE: WAVE

The WAVE module generates classic "vintage" synth waveforms with up to 5x unison. It acts like an analog oscillator

You can **DETUNE** the unison voices. For example you can use this to create super-saws.

UNI chooses the amount of unison voices.

MIX blends in the generated wave with the original signal. For example you can chain 2 WAVE modules for 10x unison.

You can choose the waveform: SAW, SQUARE, TRI, SINE and NOISE.



You can **SPREAD** the unison voices in the stereo panorama.

OCT transposes some of the unison voices by octave(s)

RAND randomizes the phase at note-on. Activate this to avoid a "zip" like start of the wave.

PM is pulse-width modulation for the **SQUARE** wave. For **TRI** and **SINE** it distorts the phase to make the waveform more sawlike. For **NOISE** it is a temporal bit-crushing effect.

You can transpose the oscillator by ± 2 octaves.

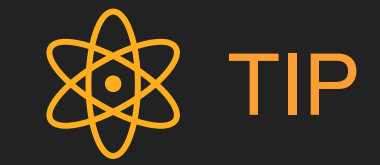

Use two WAVE modules and one LPF module, and you have a two-OSC analog modeled synth.

You can use the IRIS to add dirt and grit to make the sound more organic.

You can also create your own super-saw by using one or two WAVE modules and high unison.

MODULES: COMB and VOWEL

A comb filter is a specific kind of resonator, often used for classic physical modeling.

DAMP lowpass filters the feedback path.

FB sets the amount of feedback. It can be positive or negative feedback, which has a different sound.

There are two modes: CLASSIC is the normal mode. PHYSIS has a different tonal character, and the FB behaves differently.

HARM influences the inharmonics in the signal.

VOWEL is a filter that creates formant peaks in the frequency spectrum that are similar to the ones of the human voice.

This shifts the formants up or down.

Choose the vowel. It can be fun to modulate this.

The amount of vowel-filtering.



MODULE: SWEET / J-60 / MELLOW

These modules can be used to add a subtle or not so subtle chorus effect.

The JUNO 60 is an iconic vintage synth from Roland ([Wikipedia](#)). It contained a special chorus effect which became its signature sound. The J-60 module in MYTH is a virtual analog model inspired by this chorus.

It is a cheat-code, as it can make almost everything sound better.

SWEET will make most sounds just ... sweeter. Used with subtle amount it can give a very modern and velvety sound.

High values of SUGAR create Ligeti-like detunings for an eerie or haunting sound character.

Simply the amount of the effect applied.



MELLOW uses a barber-pole flanger that creates movement for the sound and also adds a velvety character.

This works on a broad range of source material, provided that it contains at least some overtones.

It does not wash away transients, hence it's also great for leads and basses, where it can add movement or create a very modern sound.

MODULE: CLOUDS + REVERB + SHIMMER

There are three different types of REVERB modules available.

CLOUDS is inspired by a reverb plugin called *CLOUDSEED* by [Valdemar Erlingsson](#). It's great for epic ambient reverbs with long or even endless tails.



TIP

If you find a nice setting you can save / restore it via the burger menu ☰

REVERB is a simple vintage reverb inspired by the 80s algorithmic reverbs.



SHIMMER is a shimmer effect. It uses a pitch shifter within a feedback loop and can create angel-like clouds of sound, but also dark or dissonant textures.

MODULE: LOOPHOLE

LOOPHOLE consists of six parallel micro-loopers with incommensurable delay times.

It's very much fun ... you can take something plain (like a sine), and use a LOOPHOLE module. Just by playing a few notes and tweaking some transformers with the mouse you will get interesting sound textures.



LOOPHOLE is inspired by a plugin called [Weeping Wall](#) by [Aqeel Adam](#), which has much more functionality and works great on synths and keys as well as on other acoustic instruments like guitar.

With low **DENSE** you get stuttering echoes.

With high **DENSE** and **DECAY** you create very organic "freezes"

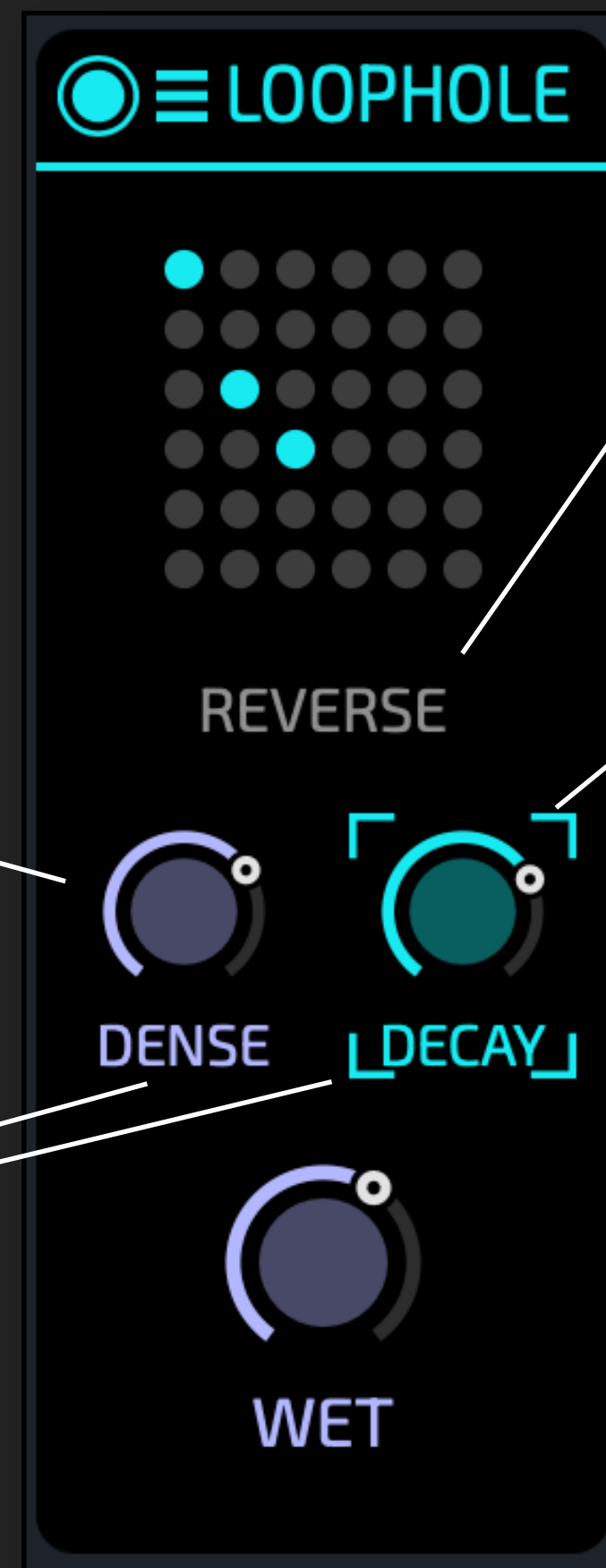

Activate for **REVERSE** playback.

DECAY on full will loop forever, but new audio material is also slowly fed into it

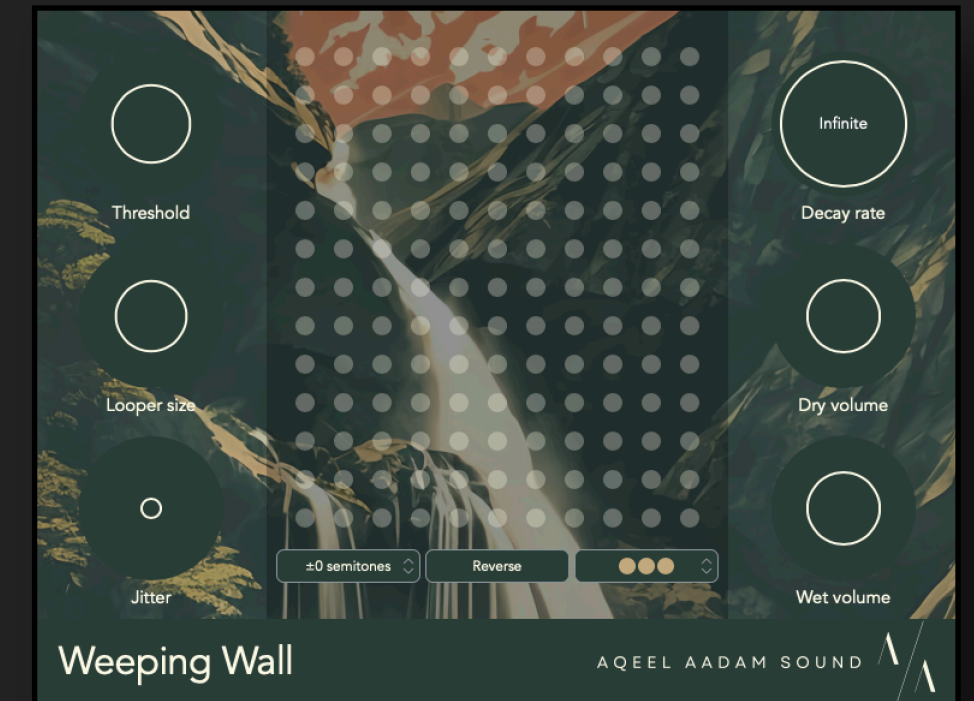

MODULE: GRAINS

This is basically the *SWARM* mode of the plugin *LOVE* as a module.

GLITT sets the probability that a grain is pitched an octave up (turn right) or down (turn left). In center position all grains are played back at their original octave.

JIT adds randomness to the grain creation. With low values the grains play at a steady rate, with high values it is chaotic.

Simply the amount of the effect applied.



Each grain gets its own tuning. This parameter controls how much the tuning is offset. High values create Ligeti-like clouds of dissonances.

CALM controls the grain duration from very short to very long and also the grain density. Turn fully right for smooth sound and long tail.

MODULE: ORBIT

ORBIT is a new type of modulation effect. It shares similarity with (analog) ring modulation and frequency modulation, but has its own unique character.

Sonically behaves in a similar way as the **RATIO** of classical FM.

Technically it controls the ratio between the frequency of the moon orbits to the frequency of the planet orbiting the sun (see explanation to the right)



FLUX can be used to add inharmonics to the sound.

Technically this works by adding a fixed frequency to the moon's orbiting speed - this desynchronizes the orbits of the celestial bodies.

CHAR - the ORBIT effect is most pronounced in center position. There are two different ways to tone down the effect by either turning right or left.

Technically this influences the ratio between the sun-planet distance and the planet-moon distance.

PARABEL

HOW IT WORKS

If you happen to own the KULT synthesizer you can use a sine OSC and then apply FM or AM. You will see that this transforms the signal trajectory by adding curves and spirals.

The orbit modulation interprets the incoming signal as a planet orbiting the sun. It then adds a moon to this planet and follows the moons trajectory. This new trajectory is then transformed back to sound.

Like a real moon, its orbits around the planet can be circular or elliptical, as well as centered or off-center. This can be chosen with the modes.

There are three different modes - each with its own sonic character. You don't need to understand the theory behind this, but it's explained here.

MODULE: OTT

OTT stands for Over-The-Top and has become a standard technique in modern electronic music.

This module is a multiband-compressor and can be used to add texture, punch or saturation to a signal.

Its available in the OSC and FILTER section - hence you can use this per voice.

Turned to the **LEFT** this is (aggressive) upwards compression: silent signals are made louder. This can be used to bring up texture in the sound or bring out silent parts like tails.

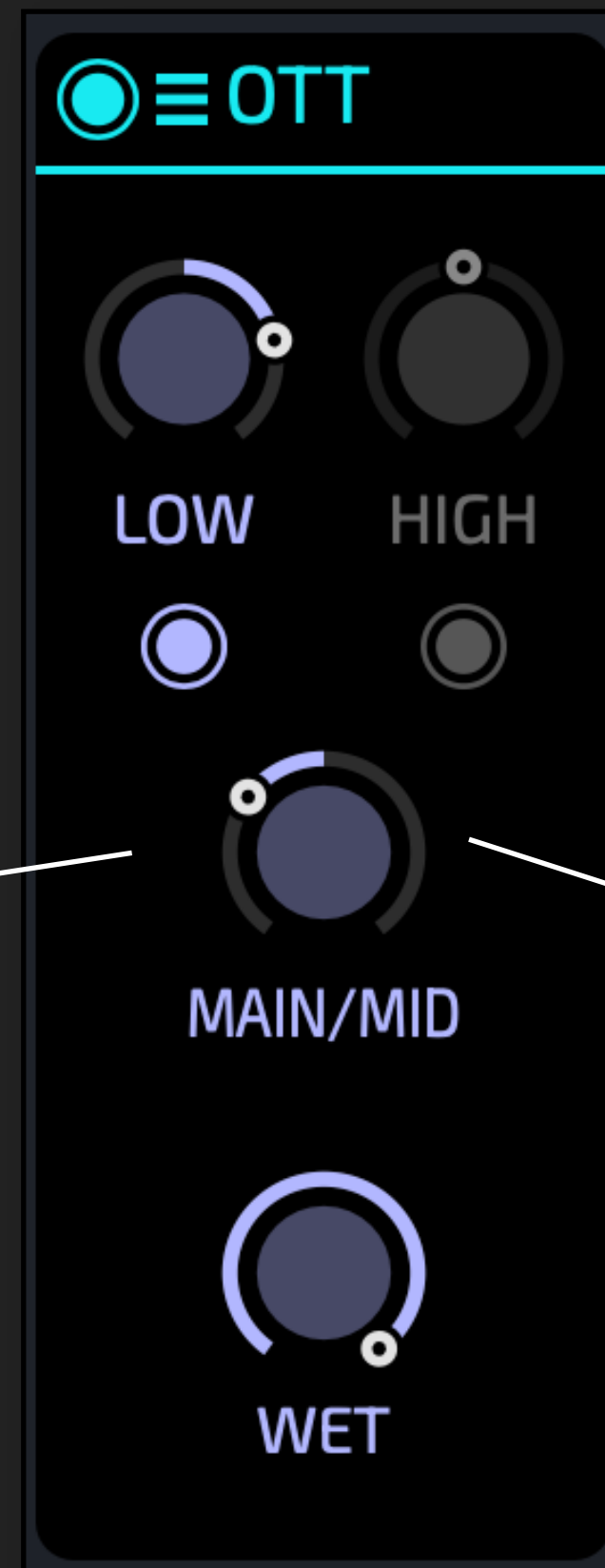

Turned to the **RIGHT** this is "normal" downwards compression: loud signals are reduced to compress the signal. Gives punch.



MAIN/MID applies to the entire frequency range.

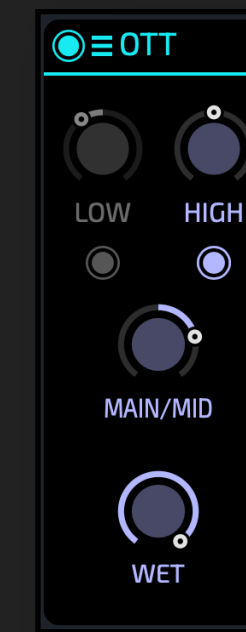

MAIN/MID applies to the low end and mid range. Separate dial for high range.

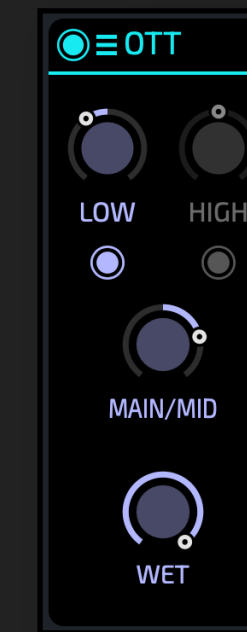

MAIN/MID applies to the high end and mid range. Separate dial for low range.



Separate dials for each of the bands.

⚡ CAUTION ⚡

When you turn a dial to the left it is doing upwards compression. That is: silent signals get dramatic amplification. Be careful with very silent tails when you put the OTT in the FX section.

MODULE: FM

FM uses the incoming signal to modulate a low frequency sine wave. This can be used to create metallic and inharmonic tones, to add sharp overtones, or to animate a static signal.



TIP

To best understand this module feed it with something simple, e.g. a sine wave. You can use the INIT preset for this.



TIP

Unless you are seeking a rough and sharp sound chaining a J-60 chorus or a SWEET module can work wonders!

The incoming signal modulates a low frequency sine wave. The frequency of this sine wave can be chosen here with a wide range from ultra-slow to far into the audio range.

Low values animate the signal. Higher values create inharmonics.



SPREAD can be used to treat the LEFT and RIGHT channels differently. This can range from subtle to wild.

The amount of frequency modulation that is applied to the incoming signal.

MODULES: RM and F-SHIFT

The modules RM and F-SHIFT can be used to create inharmonic, metallic sounds, or to add motion to a sound.



To best understand this module feed it with something simple, e.g. a sine wave. You can use the INIT preset for this.

RM modulates the incoming signal with a sine wave. The frequency is set with the **RATIO**.

RIGHT-CLICK to choose from some integer ratios.

1/3	-1/3
1/2	-1/2
2/3	-2/3
1	-1
2	-2
2.5	-2.5
3	-3
4	-4

FLUX adds a fixed low frequency to the sine. It can be used to create a metallic sound.

There are two modes available: **RING** and **BELL** that have a very different sound character.

RM stands for Ring-Modulation

F-SHIFT stands for Frequency-Shift



A frequency shifter adds the same fixed frequency to all the partials of the incoming signal.

This added frequency can be set via the **LFO**, or via the **TRANS / TUNE** dials.



Set **WET** to 50% and use small values of **TUNE** to add motion to your sound.

MODULE: AM

This offers amplitude modulation. It can be used to add inharmonic character or animation to a sound.

The AM is tuned to the incoming signal. With **RATIO** you can choose the frequency ratio between the incoming signal and the signal used for modulation.

The amount of the amplitude modulation.



Normally the **RATIO** of an amplitude modulation creates harmonic tones for integer ratios, and inharmonic values in between. Hence sweeping the **RATIO** gives a pretty wild journey through all kind of inharmonics and is often of limited musical use.

This module uses the underlying technique of [shepard tones \(Wikipedia\)](#) to allow for a separation: with **RATIO** you determine how high or low the modulation sounds, with **HARM** you control the specific timbral character of the in-harmonics.



To make yourself familiar with this module start with the INIT sound, or keep all the **TRANSFORMERS** to their defaults and dial up **BLUE** to the max.

Once you have an idea how **RATIO** and **HARM** influence the sound start experimenting with the colour-transformers.

MODULES for Saturation / Distortion



These modules can be used to distort and shape the sound.

These modules can be used to shape the sound, add punch, or more overtones. All parameters can be modulated. Often these create interesting effects if used in conjunction with other modules.

ASYM offers asymmetric distortion.

CRUSH offers two sorts of bit-crushing.

NOISIFY adds different types of noise to your signal.

SATURATOR has multiple different distortion types. You can set the DRIVE.

The image shows four modules in a row, each with a title bar and several knobs:

- NOISIFY:** Features three knobs labeled PERLIN, DARK, and BRIGHT, and a larger knob labeled WET.
- ASYM:** Features one knob labeled ASYM and a larger knob labeled DRIVE.
- CRUSH:** Features two knobs labeled AMP and PHASE, and a larger knob labeled WET.
- SATURAT:** Features a knob labeled DRIVE, a cyan-colored knob labeled WARM with five dots below it, a knob labeled ATT, and a larger knob labeled WET.

Use ATT to attenuate the saturated signal, before the DRY / WET.

MODULE: ATARI PUNK

You can build DIY-synths with CMOS chips - this is fun and has a specific adorable lo-fi sound. This module takes whatever input and creates a noisy mess that sounds as if it were created with a wild CMOS circuit.

If you are looking for something subtle, you will have better luck elsewhere.



This drives the signal depending on its phase. The effect is a bit hard to explain and depends on the other knobs.

Choose how wild you want to go.

This exaggerates the SLEW of the signals, forcing it to look more and more like a square signal (just with wild frequencies).

Like all the other knobs ... a bit hard to explain and the result also depends on the other settings.

This adds crude sub-frequencies as if you were feeding your signal into a CMOS based clock divider at audio rates.



The Atari Punk Console, shortened to APC, is a popular DIY-synth circuit that uses two 555 timer ICs as an astable square wave oscillator. It is cheap, easy to build, wild fun and sounds extremely lo-fi, or in other words: you just need to experience this.

You can build entire modular synths based on this philosophy, google "lunetta DIY".

A great tutorial is [here](#). And one of the most interesting and entertaining YT series is Kristof Blåsols [Modular-In-A-Week](#)

Ah, and in case you don't know what ATARI means: go and ask your parents or grandparents.

MODULE: TRANS

This module is only available for sections **OSC1** and **OSC2**. It can be used for tuning the **IRIS** and the modules in the **OSC** section.



TIP

This module also affects the **IRIS**, hence it will always be in the left-most position of the section.



TIP

In many cases you just want to put the **IRIS** up or down in octaves. You don't need the **TRANS** module for this - just use this dial.

Tune the oscillator up or down in cents of a semitone. Modulate this with a **PERLIN** noise modulation source for sweet detuning.

Tune the oscillator up or down by octaves. It's fun to modulate this, eg with an **LFO**.



Transpose the oscillator up or down in semi-tones.

If active the **TRANSPPOSE** snaps to integer semi-tones.

If active the oscillator always plays note **C3**, regardless of the note you play. You can use the **TRANS + OCT** to change this note.

MODULE: BTTF

BTTF is a very odd and rare module. It uses FM with feedback to bring you crazy and unusual sounds.

BACK TO THE FM



To acquaint yourself with this module you should start with feeding something really simple. Start with the INIT patch or feed in a sine.

Start with individual parameters first, and then explore combinations.

Afterwards you can use the TRANSFORMERS to change the sine wave you are feeding into BTTF.

BIFF controls the amount of feedback-FM ... it can sound warm and brass like if used sparingly on very simple inputs, it can easily get harsh and brutal.

HEAVY controls the amount of FM-modulation of the incoming signal. Low values sound like a vibrato.



The FLUX capacitor controls a delay that is in the FM-feedback path. It's faithfully modeled after the original schematics by Doc Emmett Brown.

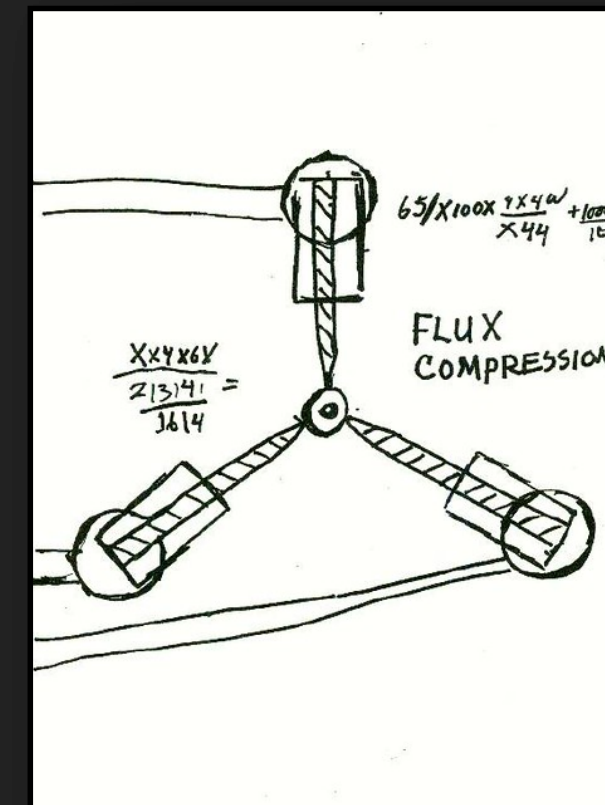

McFLY works like the ratio in classical FM, but it does not create irrational frequencies in-between, giving a more musical sweep. Works great when modulated, for example with a fast ADSR.

MODULE: GLURP

GLURP is an extension of the original GLURPY-GLORP.

It features the original "GLURP" and "GLORP" parameters, but on top it has an additional "SPILL" parameter for even more variations.

GLURP is carefully modeled to reproduce the original tonal character.

It can be used to add almost arbitrary amounts of glurpidity to your sound.

Set SPILL to the 12 o'clock position to have the original sound of the GLURPY-GLORP.



GLORP is to the GLURP what Yin is to the Yang.

The two influence each other in sometimes unpredictable ways, which is one of the reasons why it has become so popular amongst musicians.



The GLURPY-GLORP was one of the first electronic music instruments, invented in the late 1920s, but it took another 30 years before the one and only prototype was built.



The GLURPY-GLORP is now meticulously modeled after the original and available in MYTH as the GLURP module. This module can be used in the OSC and FIL sections.

Alas, the wait is over and this important iconic instrument is now available for everyone!

MODULE: ROUTE

Normally the signal flow in a section is serial from left to right. But in a few cases, you want to have parallel module chains - this can be achieved with the ROUTE module.

The ROUTE module takes the output from the previous module and directs it to the output of the SECTION.

Also, it takes the input of the SECTION and feeds this into the next module.

In the example:

The WAVE module goes into the ROUTE, from there the signal is directed to the output.

A fresh copy of the same signal that feeds into the WAVE now goes through the ROUTE into the J-60.

In other words: the WAVE is now parallel to the J-60 module.



Forget about the signal flow, just remember: the ROUTE simply "splits" the processing chain into a left and a right part that are processed in parallel.

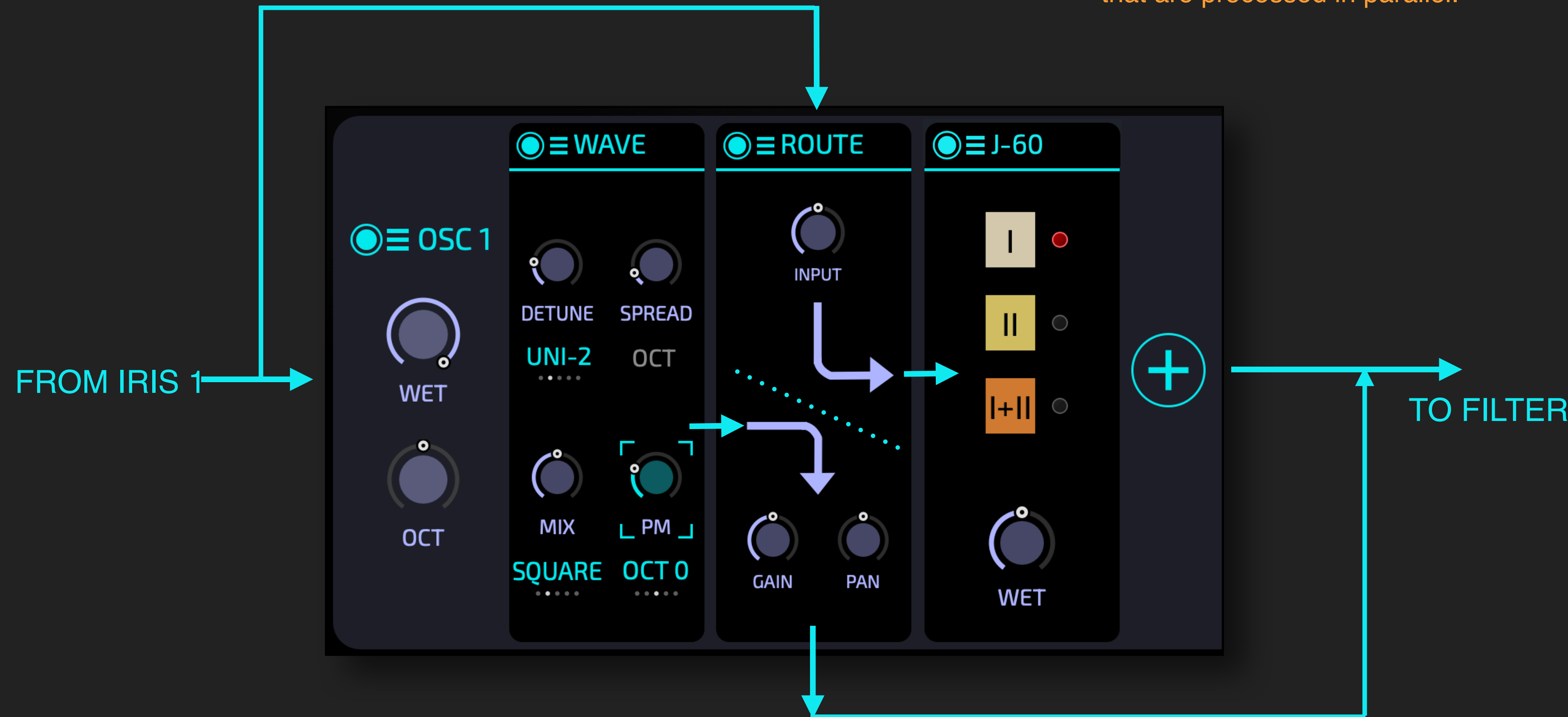

MONO MODE

The MONO MODE can be used for basses and leads that have similar behavior to monophonic analog synths.



You can drag and drop the last played notes as audio from here.



TIP

You can play a note and then drag this as audio from here to the IRIS - to get the sound re-synthesized!

Normally **MYTH** is a polyphonic synth. By activating **MONO** you can make it a monophonic synth with legato function.

With **TIME** you can control the legato speed.

When **GLISS** is active you will also have a glissando between two notes if you play legato.



Incoming notes are displayed on the virtual MPE keyboard display.

The size of the outer circle line indicates (polyphonic) **PRESSURE** or **AFTERTOUCH**.

The filled circle area indicates the **VELOCITY**.

FREEZE & RANDOMIZE



MYTH has a powerful system to create new presets from existing ones.

When FREEZE is activated, each section shows a snowflake. With this snowflake you can FREEZE the section. In this example OSC1 and FX1 are frozen. That means: if you now click on  or  these sections are not changed!

⚡ IMPORTANT ⚡

When you switch to a preset with the normal buttons the freeze state is ignored - this simply restores the preset as it was saved.



When the FREEZE mode is active you can use  and  and  to load a new preset, *but keep the frozen sections untouched*. For example, freeze the IRIS, OSC and FILTER sections. Now skip through presets to try different FX sections.

Click on the  symbol to BREED a new preset:

This takes the current selection of presets that you have filtered in the BROWSE tab ([see here](#)) and creates a new "Frankenstein" preset by randomly replacing entire sections in the current preset.

For example, you can create a selection of DARK, MYSTERIOUS PADS on the BROWSE tab and then use BREED to create more similar sounds.

Click on the  symbol to randomize the parameters of your preset. This may enable / disable modules, but it will not add / remove modules.

TIP

The longer you hold the DICE symbol down, the more deviation you will get.

PRESET PACKS

You can create PACKS from your presets and other users of MYTH can install these.

PACKS are a great way to extend the sonic capabilities of your instrument.

You can simply drag any .MythPack to the MYTH user interface to install the pack, or choose **INSTALL PACK** from the main menu.



.MythPack

DROP TO INSTALL PACK



Installed packs shows up here



TIP

You can also activate **AUTOSCAN FOR PACKS AT STARTUP** via the main menu. When you open an instance of MYTH it scans your download folder - if it finds a pack for MYTH it will be automatically installed.



TIP

It is easy to create your own packs. Simply use the file system and create a folder that contains MYTH presets. You can organize these in a single level of sub-folders, deeper nesting is ignored.

Choose **CREATE PACK ...** from the main menu. You will only need to locate the folder with your presets and a name to save the pack.



CAUTION

If you handle preset files, you should **ALWAYS** make a copy beforehand.

Better safe than sorry!

MICROTONALITY

MYTH supports two methods of retuning: MTS-ESP and MPE pitch bend.



Microtonality means tuning notes differently than the 12 equal divisions of an octave, which is the modern standard.

Many kinds of music make use of alternative tunings, but software instruments have usually been written to only play in 12-equal. In recent times this is changing, more and more instruments allow the musician to decide how the notes should be tuned.

There are many possibilities. Some only subtly different from 12-equal, some very drastically so. Happy exploring!

MYTH supports the MTS-ESP standard created by [ODDSOUND](#).



You can also retune MYTH with MPE pitch bend, typically generated by a plugin like [Entonal Studio](#) or Ableton's Microtuner. Make sure to load MYTH as an MPE instrument.

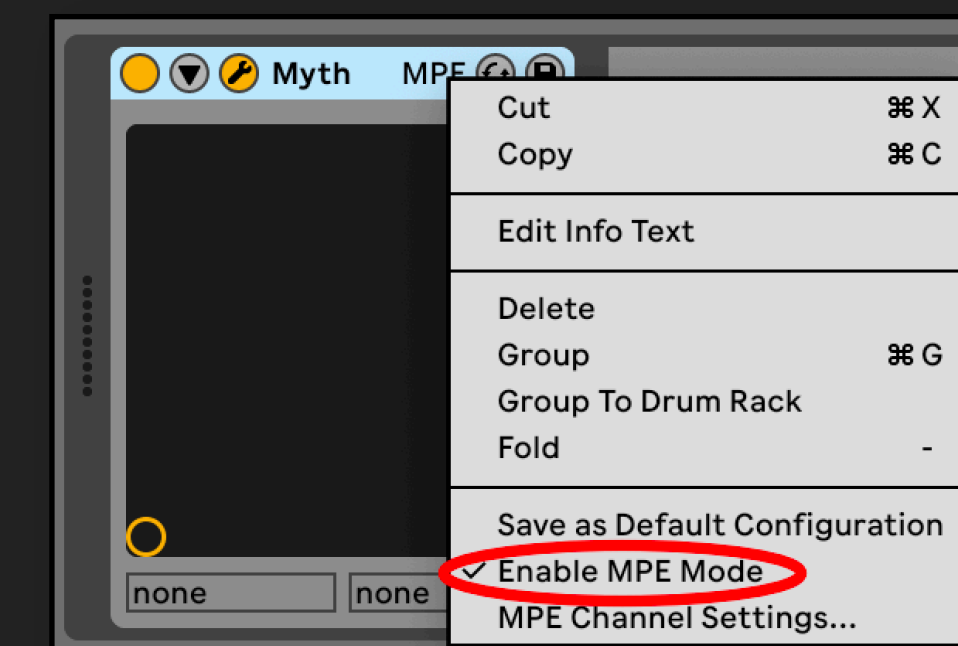

Explore different tunings with MTS-ESP

MYTH supports MTS-ESP, which allows you to easily explore tunings other than the standard 12-TET. You'll need an MTS-ESP source to set the tuning, for the following example we'll use the (free) MTS-ESP Mini.

1 INSTALL / PREPARE

Install the [free MTS-ESP MINI](#) from ODDSOUND

Download some scales:

- [the Surge Synth Team collection of Scala SCL and KBM files](#)
- the [Sevish Tuning Pack \(v1.1\)](#) contains another small curated collection of tunings for intonation explorers
- The [Scala Scale Archive](#) is a large collection of over 5100 scale files

This should be sufficient to get us started and last through several music making lifetimes!

2 HAVE FUN

In your DAW create one track and add one instance of MTS-ESP Mini. This track does not need to be armed for recording.

Load an instance of Myth on any adjacent track. Arm it to receive MIDI input from your controller.

Now extract some of the above SCL-KBM files on your computer and arrange them so they are easy to drag-and-drop into your DAW.

Drag-and-drop "HD2 06-12.scl" from the Surge XT Tuning Library onto the UI of MTS-ESP Mini to get a feel for how it works. This should instantly tune **MYTH** to the scale.

Now play across the range to hear the new intonation.



Working in 12-equal, no extra effort is needed to make each software instrument play the same tuning; they (almost) all play 12-equal by default. Working in other tunings however, up until now we've had to manage the tuning of each instrument individually.

When the goal is for all instruments to play in the same tuning this gets very repetitive, albeit doable. MTS-ESP fixes that. It's the closest thing today to a central DAW-integrated tuning feature: set the tuning in one place, all the instruments follow suit. Just like setting the tempo and time signature.

If the MTS-ESP source supports it, you can also change the tuning on the fly (with automation or MIDI), for example slowly changing key from G to Bb over the course of 6 minutes.



I recommend the [Surge Synth Team tuning Guide](#), which lists all MTS-ESP plugins.

FAQ / Troubleshooting

Q: I installed MYTH, but it does not show up in my DAW?

A: In most DAWs plugins are listed by manufacturer name. You find **MYTH** listed under **DAWESOME**. If this does not help - please make sure that VST3 (or AU) is activated in your DAW.

Q: I am experiencing audio drop outs - what a lousy plugin!

A: I can understand your frustration! Rest assured that I spend an insane amount of work to make the underlying technology CPU efficient and to support aged hardware and OS versions. [Please drop me a short description to peter@dawesomemusic.com](mailto:peter@dawesomemusic.com) - ideally with the information of your computer, your DAW, your OS and the specific preset that causes the issue.

Q: The UI looks pixelated / distorted

A: In the main burger menu in the upper left there is an entry to **DISABLE OPEN GL**. Please try to activate this setting, then reload your project - the plugin needs to be reloaded to make this change active. If you are using **Ableton LIVE**: make sure that "Auto-Scale Plug-In Window" is **NOT ACTIVATED**.

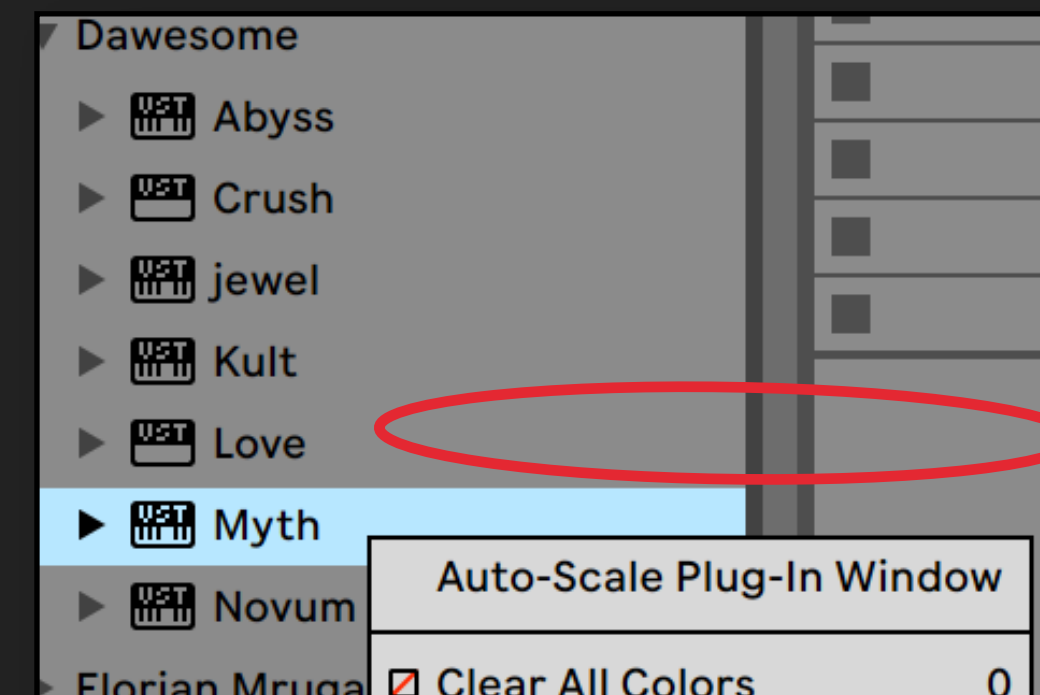

Q: I can't hear anything!

A: First make sure that **MYTH** receives midi data - you can see incoming midi on the virtual keyboard. Make sure that the OUT is not set to zero.

FAQ / Troubleshooting

Q: Why are all your plugins so expensive - you are ripping me off!

Q: Why are all your plugins so cheap - this is too good to be true?

A: I am a single person indie developer. Mainly I follow my heart and create the instruments I'd like to use on my own as a musician. I do not aspire to get rich in money with it, I aspire to get rich in contentment and fulfillment. However, I also need to pay my bills, and I also want to pay sound designers fairly for their work. I am trying to give my products the lowest prices possible to make a living, and I am not going to be a millionaire anytime soon (well, ever).

There is a 90 day free trial. During this time there is an almost 100% chance that there will be a SALE with massive discount.

Q: I have a question / feedback - where can I leave it?

Q: I have a cool idea for a great feature!

A: Just drop me an email to peter@dawesomemusic.com - I appreciate any kind of constructive feedback and I am trying my best to have any user satisfied, regardless whether you purchased or not. Usually I try to answer within a few days.

If you want to share any idea with me please drop me an email to peter@dawesomemusic.com. Please note that I may have had the idea before and hence I won't pay you license fees if I choose to implement this idea or a related idea in one of my plugins. If you believe your idea has tremendous commercial potential make sure to get a signed agreement *before* sharing the idea with me / anyone.

Q: I like your work - how can I support you?

A: Thank you - this is my real reward for the work I am doing! I hope you will find lots of fun and inspiration with MYTH or any other of my plugins. If you want to support me: spread the word - many (most?) people simply have not heard about DAWESOME.

Or send me a brief message via mail to peter@dawesomemusic.com - this will certainly cheer me up!

CREDITS - THANK YOU!

- [MYTH](#) is implemented in C++ using the [Juce Framework](#). I am grateful for its existence and for the community of JUCE developers.
- [Valdemar Erlingsson](#) is the creator of the gorgeous free reverb plugin called [Cloud Seed](#). I took inspiration from his work for the CLOUDS FX
- [Nigel Redmon](#) has published an intriguing [series](#) about analog ADSRs. I took inspiration and design choices from his series.
- [MYTH](#) uses the awesome AVIR image resizing algorithm designed by [Aleksey Vaneev](#) of Voxengo
- Sample rate converter designed by [Aleksey Vaneev](#) of Voxengo
- The lava image in this manual on page 2 is from [Brent Keane](#)
- [c0nsilience](#) provided feedback on early version and some samples
- [Rich Whitfield](#) and [Frank Gesang aka SiL3NC3](#) and [Saf Ro](#) and [DATABROTH](#) painstakingly proof read this user guide
- [DATABROTH](#) + [Spektralisk](#) + [HydraTek](#) + [Rich Whitfield](#) have provided extensive feedback / discussion of various features over a long time
- [Sound Author](#) + [Sabastian Weaver aka Azure Eyes](#) gave feedback to improve features and had some very cool feature requests
- [BIANSU](#) created the official trailer track for MYTH
- [Jacky Ligon](#) convinced me to add MTS-ESP support and provided tons of inspirational use cases and validated the MTS-ESP implementation
- [Oli Cash from OddSound](#) provided the lib for MTS-ESP and answered all my questions
- [Jacky Ligon](#) and [Andreya](#) provided the Microtuning and MTS-ESP explanation in this user guide
- [Jacky Ligon](#) and [Sound Author](#) have provided samples for the modal filter / resonator

I am blessed with an awesome group of [Beta Heroes](#) who found bugs and provided many ideas:

[Rich Whitfield](#)
[Cool WAV](#)
[Tomavatars](#)
[sadà'exposadà](#)
[Astralmuse](#)

[DATABROTH](#)
[EI°HYM](#)
[Andreya](#)
lab by the sea
dreamerOnGo

[Spektralisk](#)
[Saf Ro](#)
Squaremoons
David Henkel

[HydraTek](#)
[Florian Mrugalla](#)
Mathias Brüssel
[BIANSU](#)

[Sound Author](#)
[HiEnergy](#)
Philip Rampi
[Jacky Ligon](#)

[Alessandro Cardinale](#)
[Frank Gesang aka SiL3NC3](#)
[David Lilja \(PaleSkinnySwede\)](#)
[Sabastian Weaver aka Azure Eyes](#)

ABOUT DAWESOME



My name is **Peter** and I am the creator behind all Dawesome plugins.

I am a musician at heart, playing the bassoon and contrabassoon in multiple ensembles and I have a lifelong passion for synthesisers.

With a PhD in maths I can proudly call myself a professional nerd.

A few core principles that drive my work:

- **Creativity can and should be fun**
- **Sense and Simplicity** (is the outcome of hard and complex work)
- **Exploration is the royal road**

PS: you can always contact me via peter@dawesomemusic.com

Peter ✓

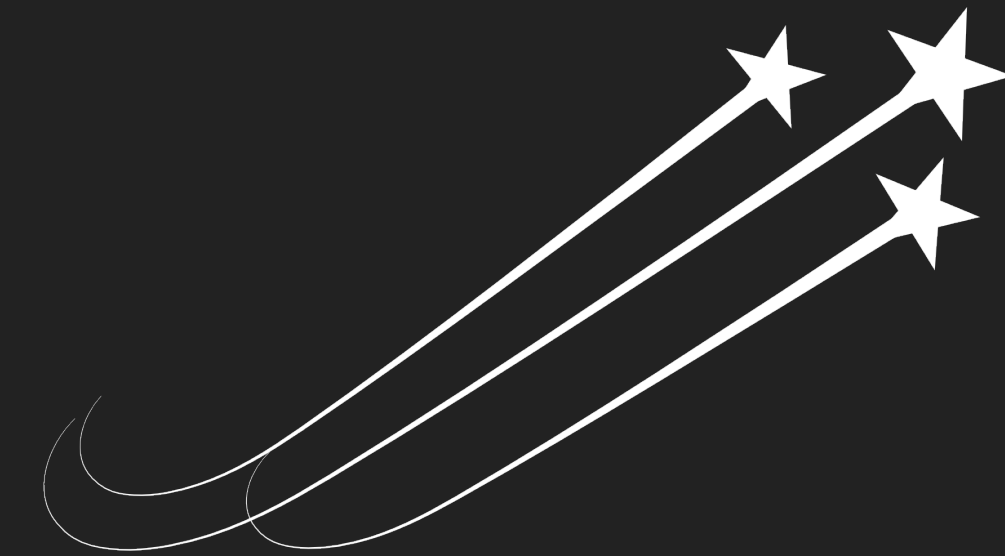

DAWESOME



TIP

Spending my time on creating plugins instead of running marketing campaigns and spamming your inbox is more fun ... for me and probably also for you.

Please support our work by spreading the word!

Dawesome Village

... is the **friendly and supportive community for sound lovers** on Discord!

You can join by clicking on the invitation link below. You will find many interesting people, tons of information, many freebies like sample packs and presets and much more...

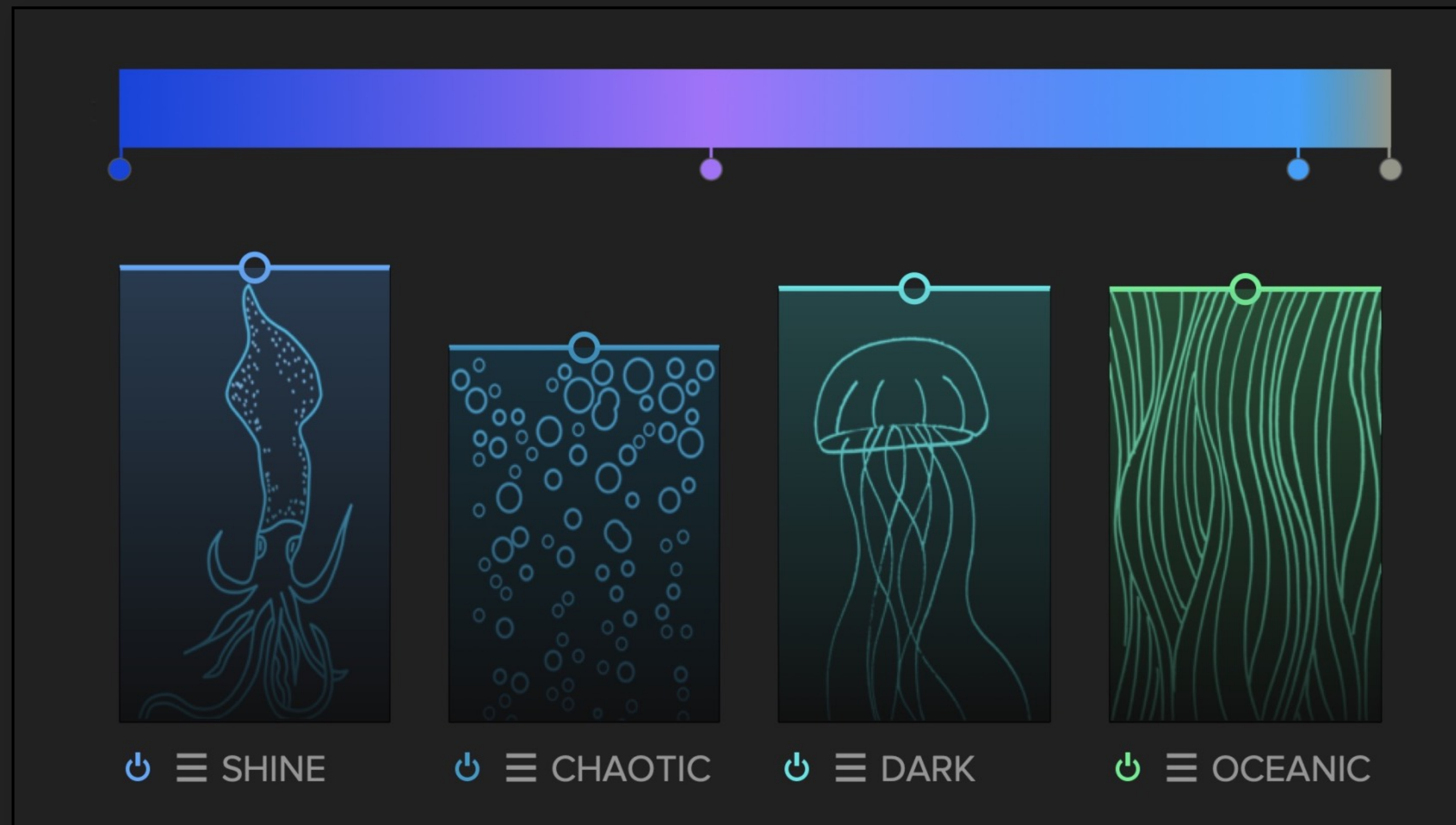

Invitation Link: [Dawesome Village](#)

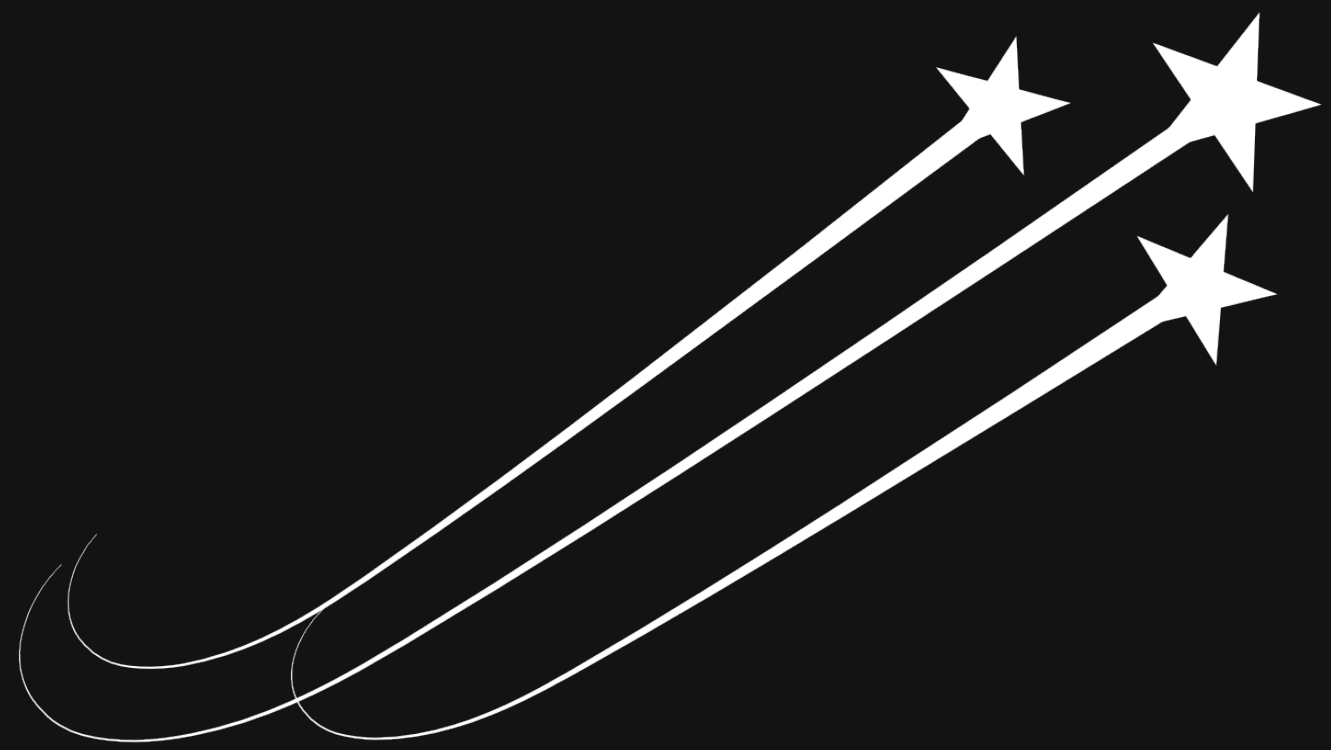

DAWESOME